

2 - Trays loader

CODE	DESCRIPTION
100269	SPEED REDUCER LEFT 0,12KW
100270	SPEED REDUCER 0,12KW RIGHT
170331	PULLEY FOR POLYCORD
341635	RIGHT TABLE
341636	LEFT TABLE
342032	CONVEYOR SPINDLE
342033	SPINDLE
370303	PHOTOCELL
410502	SUPPORT UCFA 204 D.20
441130	KEY
451118	ELASTIC PIN 4X40
620701	CONVEYOR SPINDLE
620702	SPINDLE

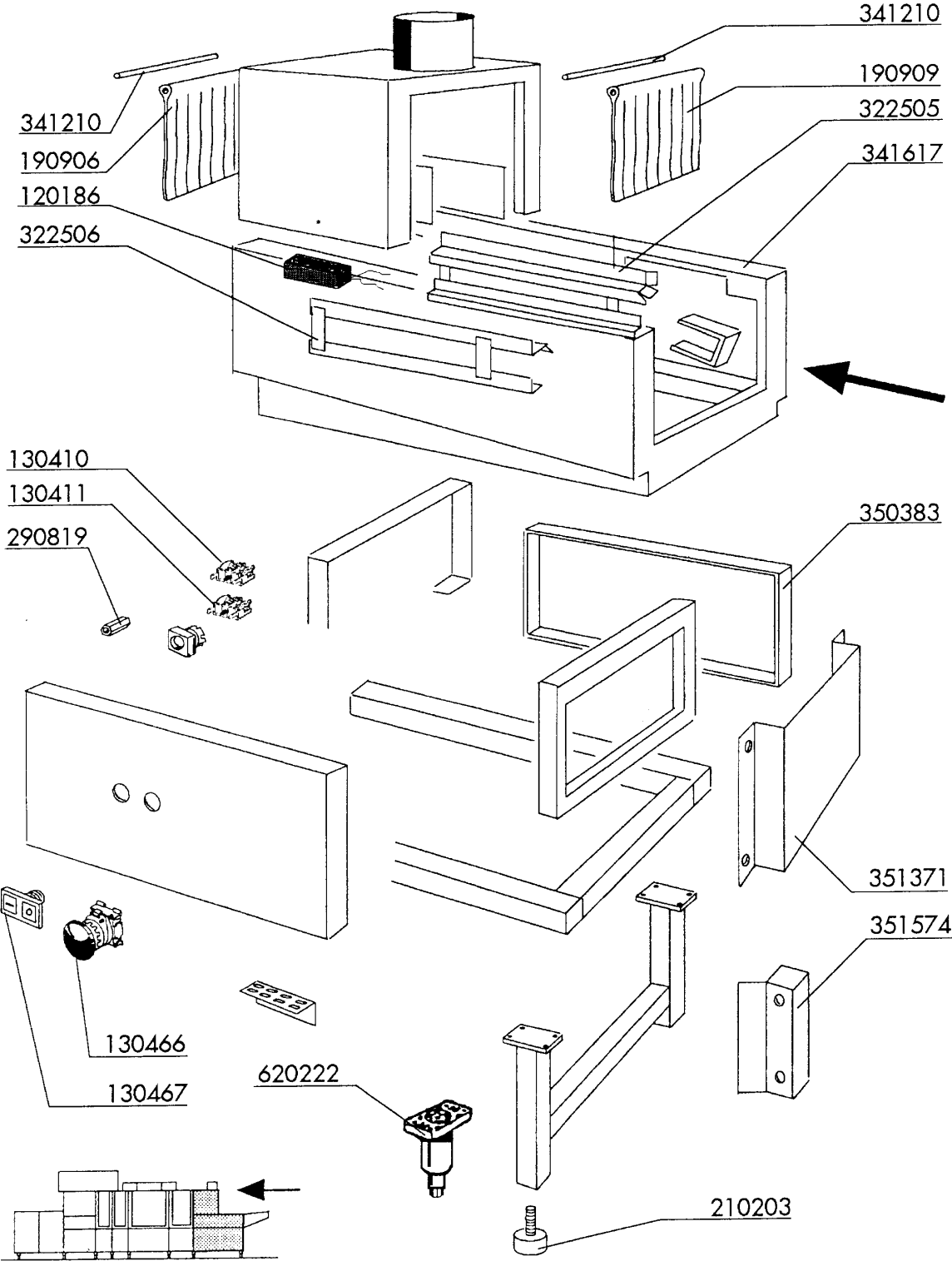

3 - Loading table

CODE	DESCRIPTION
120186	DEMAGNETIZER
130410	STOP CONTACT F40 CN RED
130411	START CONTACT YELLOW
130466	EMERGENCY SWITCH
130467	DOUBLE PUSH BUTTON
190906	CURTAIN IN/OUT 620X480
190909	ANTI SPLASH CURTAIN (ENTRY)690
210203	RUBBER FOOT 30 MM
290819	SPACER
322505	GUIDE
322506	GUIDE
341210	CURTAIN SHAFTS N 2S GM
341617	ENTRY TABLE
350383	PANEL
351371	PANEL
351574	CORNER PANEL
620222	COMPLETE ALUMINIUM LEGS

4 - Prewash Hood

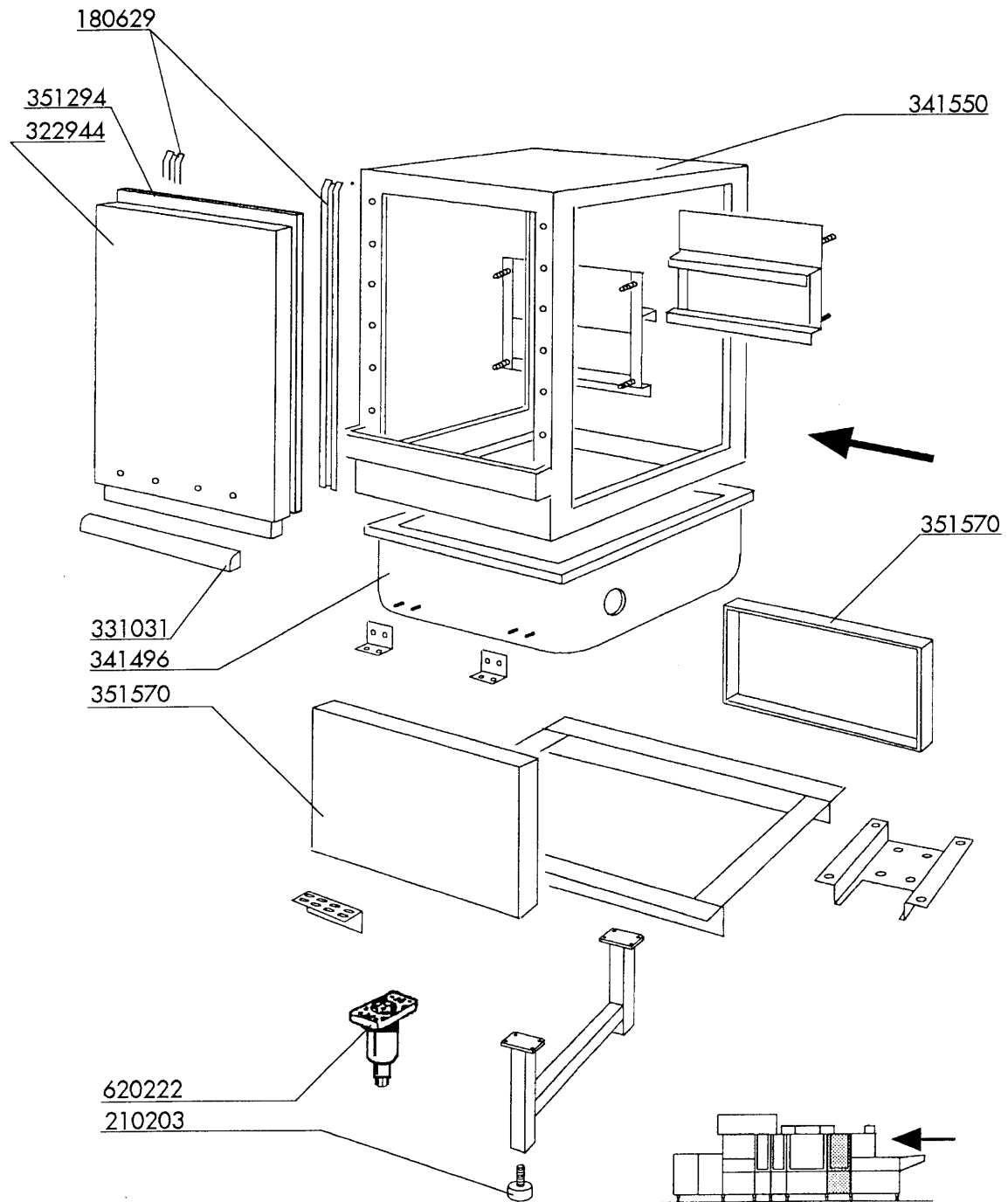

4 - Prewash Hood

CODE	DESCRIPTION
180629	DOUBLE SKINNED DOOR RUNNER -NE
210203	RUBBER FOOT 30 MM
322944	DOOR NE 600
331031	600MM DOOR HANDLE ACR/NE D.SKI
341496	PREWASH TANK
341550	HOOD
351294	INSULATED PANEL
351570	PANEL
620222	COMPLETE ALUMINIUM LEGS

5 - Prewash Column

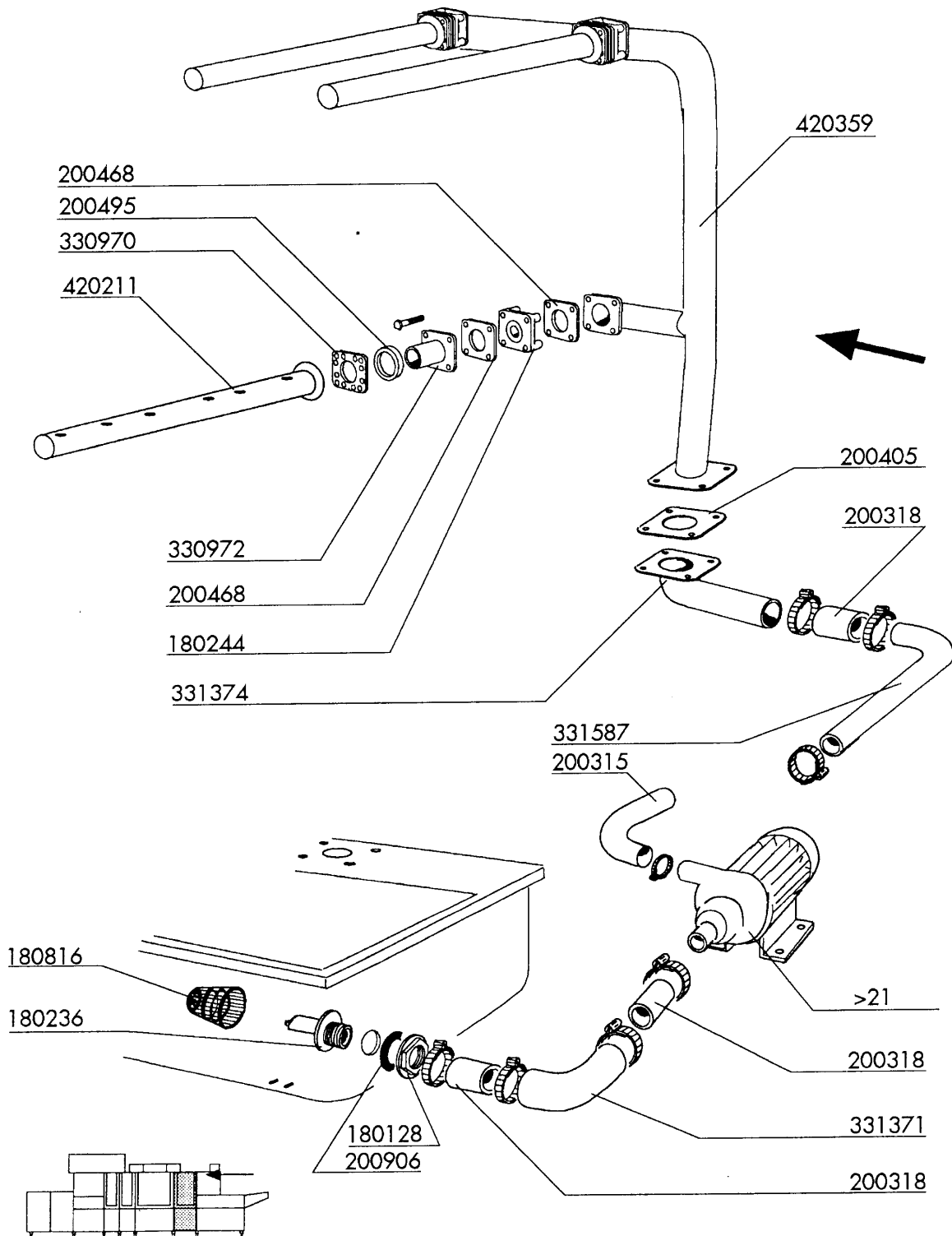

5 - Prewash Column

CODE	DESCRIPTION
180128	RING NUT 65,4 C140 C85
180236	PUMP SUCTION FOR AC-ACR-C155
180244	FLANGE WASH ARM LV-LVP
180816	STRAINER OF INLET PUMP AC-ACR
200315	OUTLET HOSE C34-35
200318	INLET HOSE 64X76 C34 SE
200405	GASKET 110X100X63 IN NEOTEN
200468	GASKET 70X70X3 NEOTEN NE
200495	GASKET FOR ACR S/S WASH ARM 43
200906	GASKET D.92X66X2
330970	FLANGE
330972	FLANGE
331371	N WASH INLET ELBOW
331374	DELIVERY ELBOW PREWASH N
331587	DELIVERY ELBOW AC-ACR WASH
420211	UPPER WASH ARM
420359	PREWASH ARM

6 - Prewash Tank

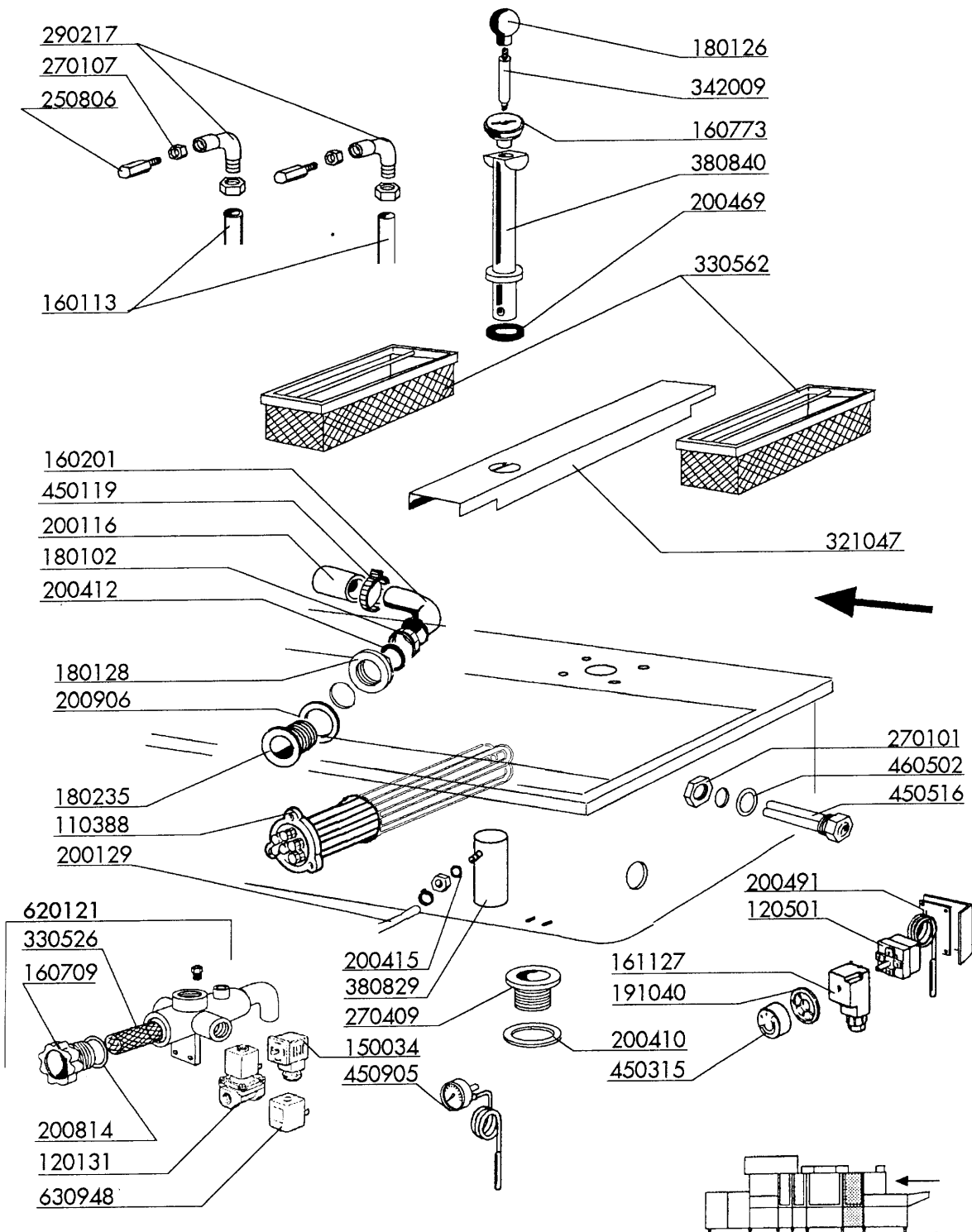

6 - Prewash Tank

CODE	DESCRIPTION
110388	HEAT.ELEMENT 10000W 230/400V
120131	SOLEN. L182Q31-ZB10A 1/2"24V
120501	THERMOSTAT 30/90°C
150034	CONNEC.F.SOLEN.VALVE 122.09.N
160113	TUBE IN POL. RETIC. 12 EST
160201	ELBOW F.TANK INLET MOPLN
160709	KNOB OF MANIFOLD F. SOLEN. VAL
160773	PLUG FOR OVERFLOW PIPE
161127	BOX FOR THERMOSTAT
180102	DRAIN PIPE NUT 1"1/2 F45-55
180126	HANDLE F.OVERFLOW PIPE SNL
180128	RING NUT 65,4 C140 C85
180235	PUMP SUCTION C85-140
191040	FRAME F.THERMOSTAT KNOB
200116	RUBBER HOSE 60X70
200129	HOSE 5X11 FOR PRESSURE SWITCH
200410	DRAIN OUTL.WASH.1 1/2"65X47X2
200412	GASKET DRAIN 11/2" 45X33X3
200415	AIR TRAP GASKET -F2 18,5X10X3
200469	STAND PIPE O RING 45X35,5X7
200491	BACK GASKET OF THERMOSTAT BOX
200814	O-RING 34,52X41,58X3,53
200906	GASKET D.92X66X2
250806	TANK FILL HOSE CLAMP - AC/ACR
270101	HEXAGON LOCK NUT 1/2"
270107	BRASS LOCK NUT 3/8" FL803
270409	DRAIN OUTLET AC-ACR
290217	HOSE CLAMP ELBOW 12X3/8" TYPE
321047	GUIDE
330526	FILTERS 22X28 SOLENOID V.MANIF
330562	FILTER DRAWER PRE-WASH.NE
342009	OVERFLOW SPACER WASH TANK AC-A
380829	ST/ST AIR CHAMBER FOR NG-NE
380840	OVERFLOW PIPE
450119	CLAMP FE ZN. 58-75 H=12,2
450315	KNOB F. THERMOSTAT 90°
450516	THERMOSTAT SHIELD FOR 2 TERMOS
450905	CAPIL.THERMOMETER D.52 1,5M
460502	GASKET 30X21X2
620121	TWIN SOLENOID VALVE MANIFOLD
630948	COIL Z610A 24V 50/60-L180V01

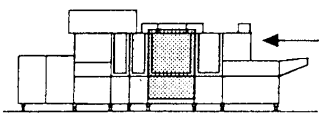
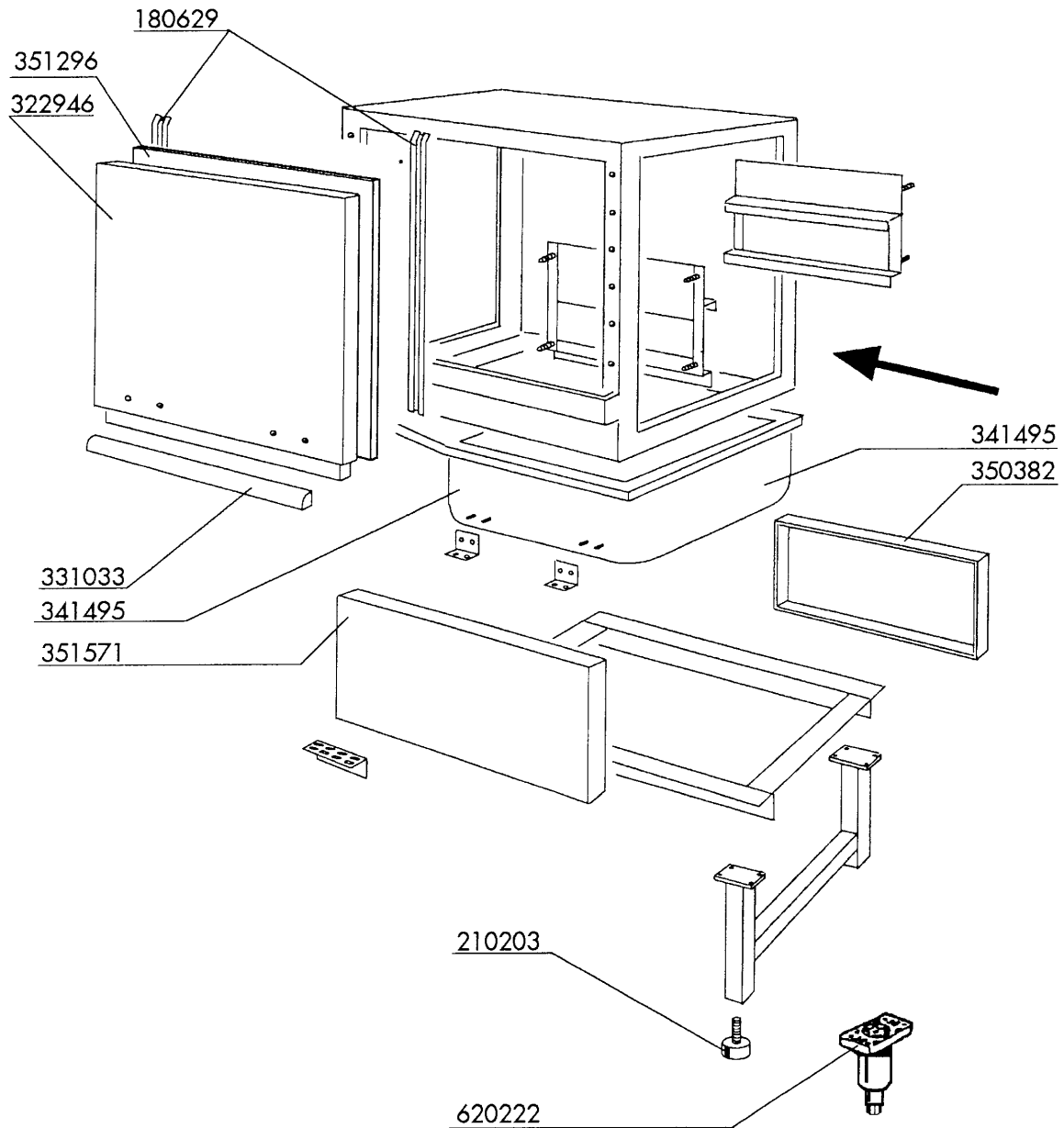

7 - Wash Hood

CODE	DESCRIPTION
180629	DOUBLE SKINNED DOOR RUNNER -NE
210203	RUBBER FOOT 30 MM
322946	DOOR NE LAV.1000
331033	1000MM DOOR HANDLE NE D.SKINNE
341495	WASH TANK
350382	PANEL
351296	INSULATED PANEL 1000MM
351571	WASH PANEL
620222	COMPLETE ALUMINIUM LEGS

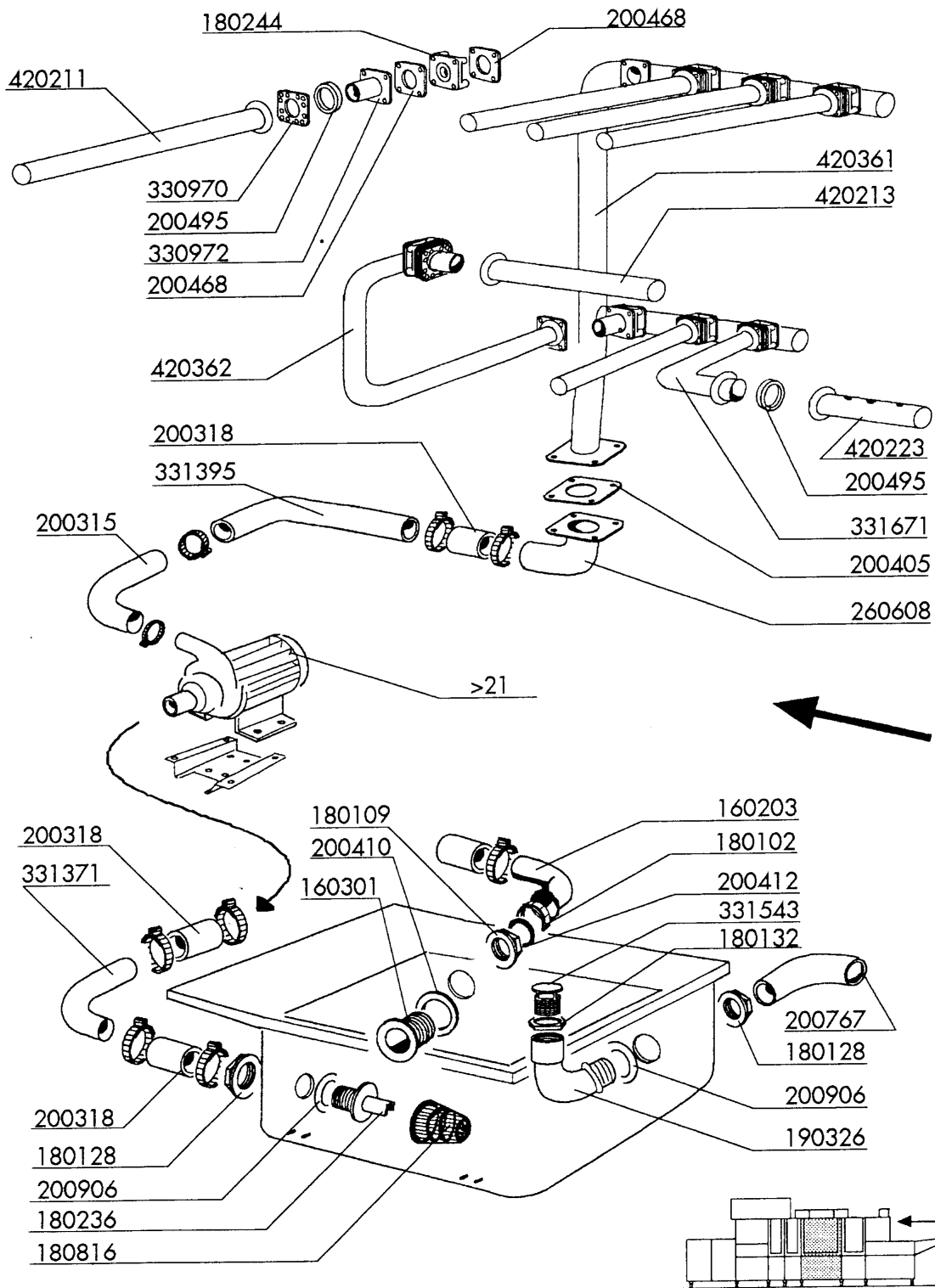

8 - Wash Column

CODE	DESCRIPTION
160203	ELBOW 1"1/2 N-S-F-C /DRAIN
160301	DRAIN OUTLET 1"1/2 C-S-N
180102	DRAIN PIPE NUT 1"1/2 F45-55
180109	LOCK NUT 1 1/2"
180128	RING NUT 65,4 C140 C85
180132	LOCK NUT 2" FOR OVERFLOW AC-AC
180236	PUMP SUCTION FOR AC-ACR-C155
180244	FLANGE WASH ARM LV-LVP
180816	STRAINER OF INLET PUMP AC-ACR
190326	ELBOW FOR OVERFLOW AC-ACR
200315	OUTLET HOSE C34-35
200318	INLET HOSE 64X76 C34 SE
200405	GASKET 110X100X63 IN NEOTEN
200410	DRAIN OUTL.WASH.1 1/2"65X47X2
200412	GASKET DRAIN 11/2" 45X33X3
200468	GASKET 70X70X3 NEOTEN NE
200495	GASKET FOR ACR S/S WASH ARM 43
200767	OUTLET HOSE WASH ACR
200906	GASKET D.92X66X2
260608	CONNECTION0
330970	FLANGE
330972	FLANGE
331371	N WASH INLET ELBOW
331395	PREWASH PUMP OUTLET HOSE
331543	OVERFLOW PIPE H=50
331671	HOSE FOR LOWER WASH ARM LVP
420211	UPPER WASH ARM
420213	WASH ARM
420223	LOWER WASH ARM
420361	WASH ARM
420362	WASH ARM

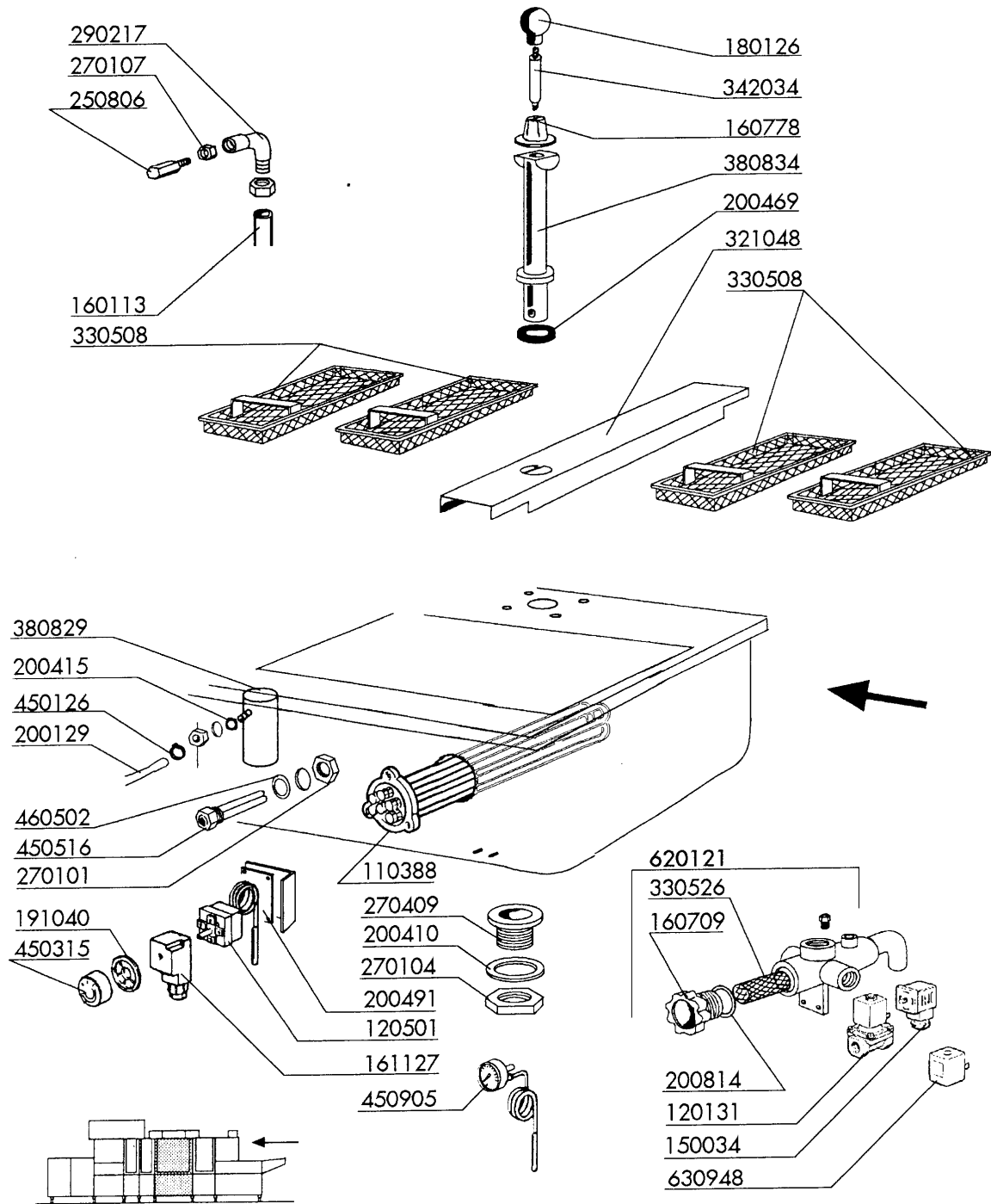

9 - Wash tank

CODE	DESCRIPTION
110388	HEAT.ELEMENT 10000W 230/400V
120131	SOLEN. L182Q31-ZB10A 1/2"24V
120501	THERMOSTAT 30/90°C
150034	CONNEC.F.SOLEN.VALVE 122.09.N
160113	TUBE IN POL. RETIC. 12 EST
160709	KNOB OF MANIFOLD F. SOLEN. VAL
160778	PLUG FOR WASH TANK OVERFLOW PI
161127	BOX FOR THERMOSTAT
180126	HANDLE F.OVERFLOW PIPE SNL
191040	FRAME F.THERMOSTAT KNOB
200129	HOSE 5X11 FOR PRESSURE SWITCH
200410	DRAIN OUTL.WASH.1 1/2"65X47X2
200415	AIR TRAP GASKET -F2 18,5X10X3
200469	STAND PIPE O RING 45X35,5X7
200491	BACK GASKET OF THERMOSTAT BOX
200814	O-RING 34,52X41,58X3,53
250806	TANK FILL HOSE CLAMP - AC/ACR
270101	HEXAGON LOCK NUT 1/2"
270104	LOCK NUT 1" 1/2
270107	BRASS LOCK NUT 3/8" FL803
270409	DRAIN OUTLET AC-ACR
290217	HOSE CLAMP ELBOW 12X3/8" TYPE
321048	GUIDE
330508	FILTER FOR WASHING + ECORINSE
330526	FILTERS 22X28 SOLENOID V.MANIF
342034	PIN FOR OVERFLOW PIPE
380829	ST/ST AIR CHAMBER FOR NG-NE
380834	OVERFLOW PIPE
450126	-CINTURINO PLAST.75X2,2
450315	KNOB F. THERMOSTAT 90°
450516	THERMOSTAT SHIELD FOR 2 TERMOS
450905	CAPIL.THERMOMETER D.52 1,5M
460502	GASKET 30X21X2
620121	TWIN SOLENOID VALVE MANIFOLD
630948	COIL Z610A 24V 50/60-L180V01

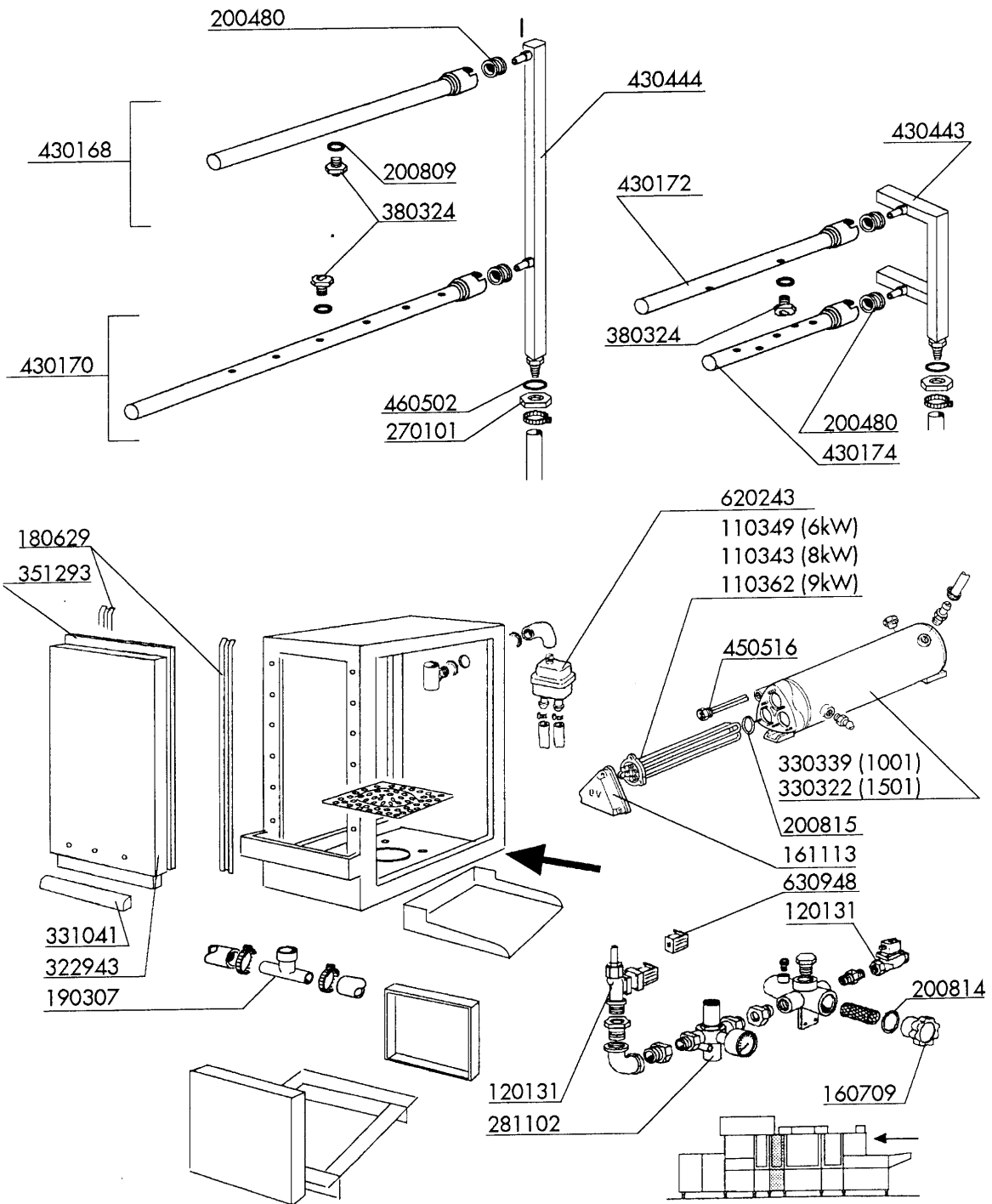

10 - Rinse

CODE	DESCRIPTION
110343	HEAT.ELEM. 8000W 220/380V
110349	HEAT.ELEMENT 6000W 230/400V
110362	HEAT.ELEMENT 9000W 220/380V
120131	SOLEN. L182Q31-ZB10A 1/2"24V
160709	KNOB OF MANIFOLD F. SOLEN. VAL
161113	ELMENT COVER BLACK
180629	DOUBLE SKINNED DOOR RUNNER -NE
190307	SPECIAL TEE GRAU MPL.
200480	GASKET F. RINSE CONNECT.
200809	OR GASKET 1,78X8,73X12,29
200814	O-RING 34,52X41,58X3,53
200815	O-RING F. HEAT.ELEM.
270101	HEXAGON LOCK NUT 1/2"
281102	1/2" ADJ VALVE C/W GAUGE TYPE
322943	DOOR NE 400
330322	INSULATED BOILER D.230 N/S
330339	BOILER D.220X640 F.TWO HEAT.EL
331041	400MM DOOR HANDLE ACR/NE D.SKI
351293	INSULATED PANEL 400MM
380324	RINSE JETS 52,5 80Ø OV1/8"
430168	UPPER RINSE ARM
430170	LOWER RINSE ARM
430172	UPPER RINSE ARM
430174	LOWER RINSE ARM
430443	RINSE ARM
430444	RINSE ARM
450516	THERMOSTAT SHIELD FOR 2 TERMOS
460502	GASKET 30X21X2
620243	VACUUM BREAKER (WITHOUT KIT)
630948	COIL Z610A 24V 50/60-L180V01

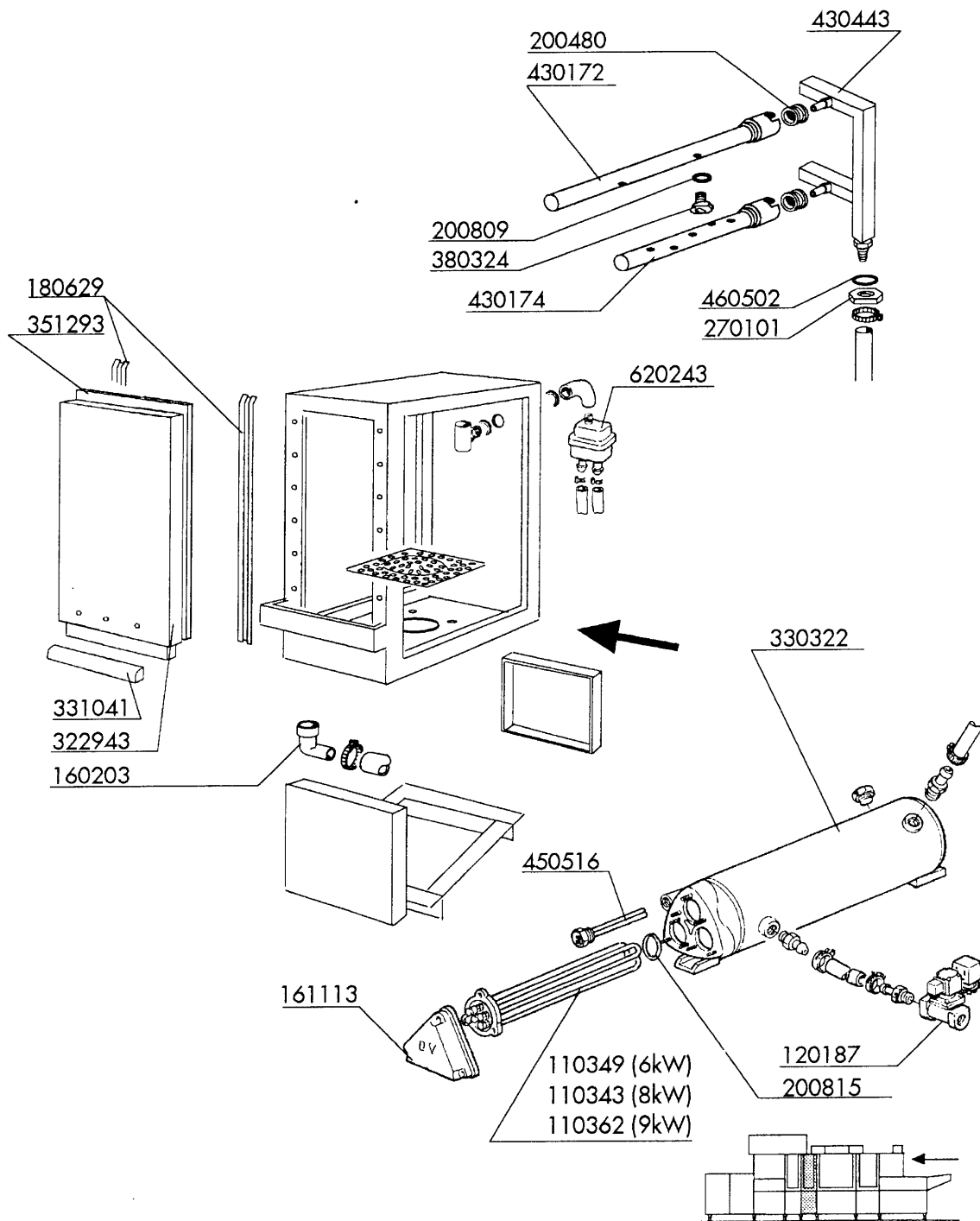

11 - Osmosis rinse

CODE	DESCRIPTION
110343	HEAT.ELEM. 8000W 220/380V
110349	HEAT.ELEMENT 6000W 230/400V
110362	HEAT.ELEMENT 9000W 220/380V
120187	SOLENOID VALVE 3/4" 24V
160203	ELBOW 1"1/2 N-S-F-C /DRAIN
161113	ELMENT COVER BLACK
180629	DOUBLE SKINNED DOOR RUNNER -NE
200480	GASKET F. RINSE CONNECT.
200809	OR GASKET 1,78X8,73X12,29
200815	O-RING F. HEAT.ELEM.
270101	HEXAGON LOCK NUT 1/2"
322943	DOOR NE 400
330322	INSULATED BOILER D.230 N/S
331041	400MM DOOR HANDLE ACR/NE D.SKI
351293	INSULATED PANEL 400MM
380324	RINSE JETS 52,5 80Ø OV1/8"
430172	UPPER RINSE ARM
430174	LOWER RINSE ARM
430443	RINSE ARM
450516	THERMOSTAT SHIELD FOR 2 TERMOS
460502	GASKET 30X21X2
620243	VACUUM BREAKER (WITHOUT KIT)

12 - Dryer for cutlery

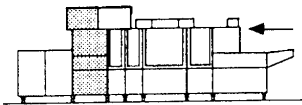
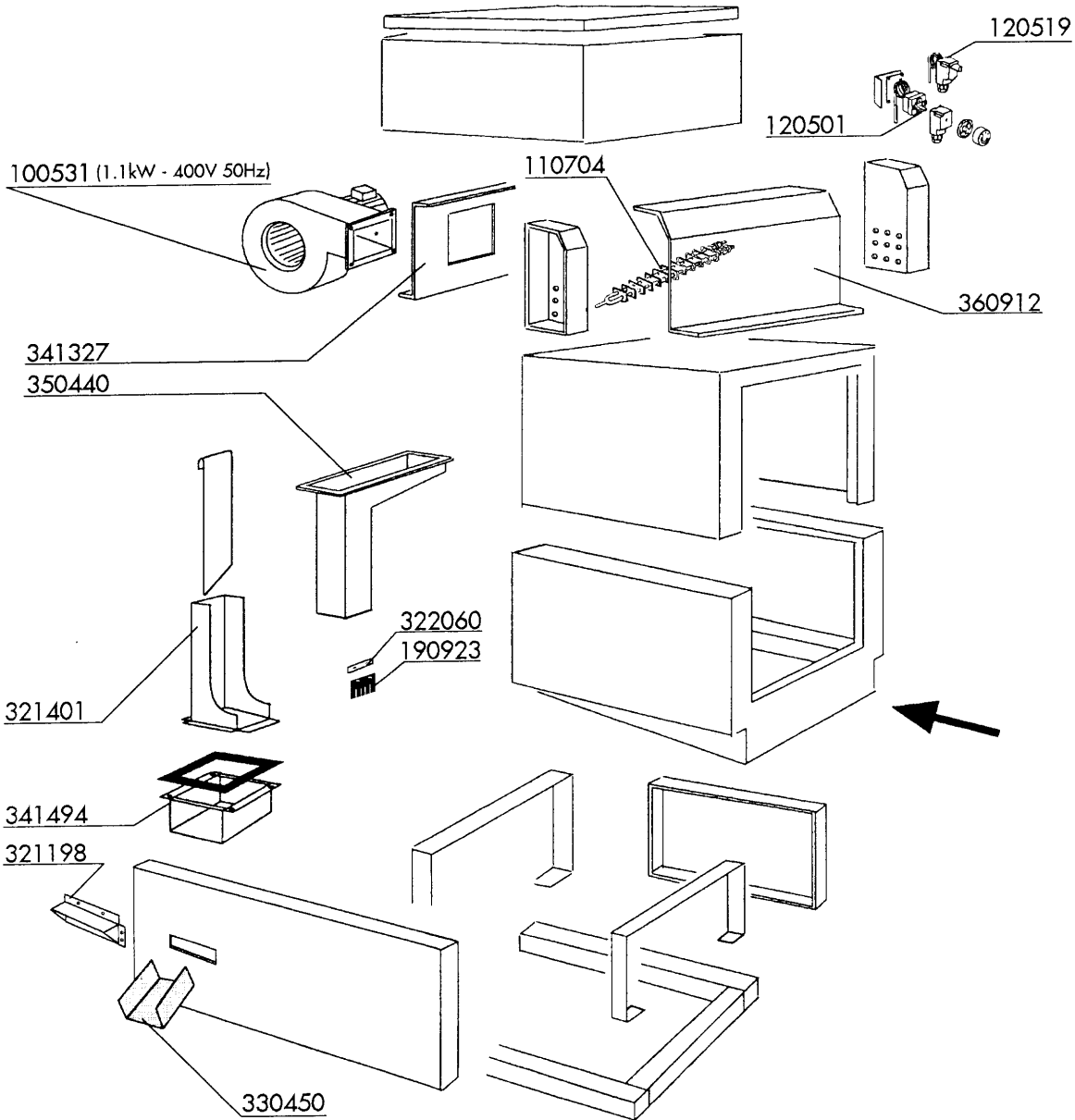

12 - Dryer for cutlery

CODE	DESCRIPTION
100531	FAN HP1,5-220/380/415-BPN9
110704	HEAT.ELEMENT/DRYING 1000W 220V
120501	THERMOSTAT 30/90°C
120519	SECURITY THERMOSTAT 95-125°C
190923	CURTAIN FOR CUTLERY SIDE
321198	PANEL
321401	DRYER CHANNEL FOR LVP
322060	BRACKET
330450	DEFLECTOR
341327	FAN SUPPORT
341494	TANK
350440	DRYER CHANNEL FOR CUTLERY
360912	BACK PANEL

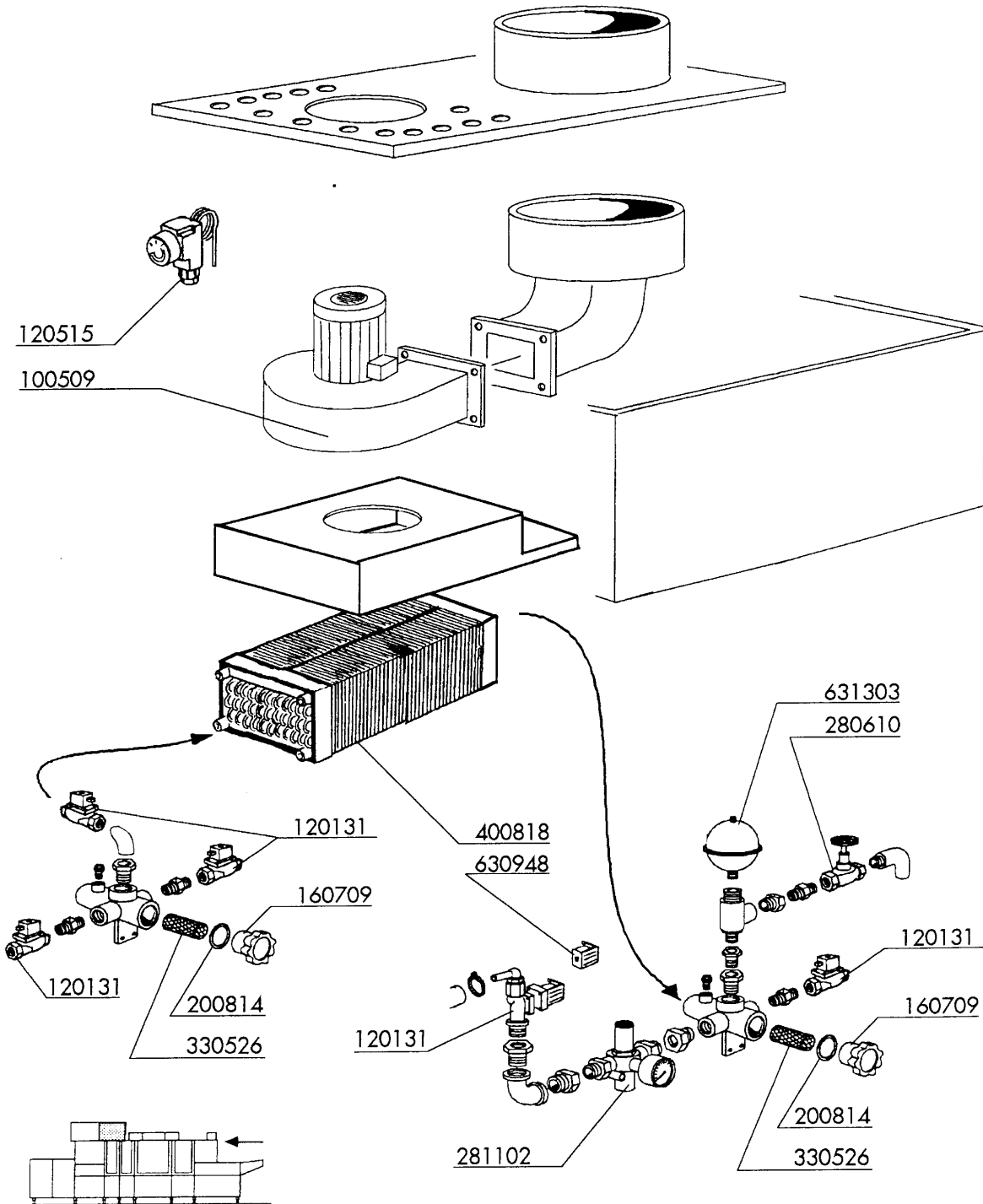

13 - Heat recovery unit

CODE	DESCRIPTION
100509	FAN 0,75HP 220/415 V164/2
120131	SOLEN. L182Q31-ZB10A 1/2"24V
120515	THERMOSTAT 0-90°C
160709	KNOB OF MANIFOLD F. SOLEN. VAL
200814	O-RING 34,52X41,58X3,53
280610	VALVE FOR HEAT RECOVERY UNIT
281102	1/2" ADJ VALVE C/W GAUGE TYPE
330526	FILTERS 22X28 SOLENOID V.MANIF
400818	BATTERY FOR HRU (SMALL)
630948	COIL Z610A 24V 50/60-L180V01
631303	HYDRAULIC AIR VESSEL FOR HEAT

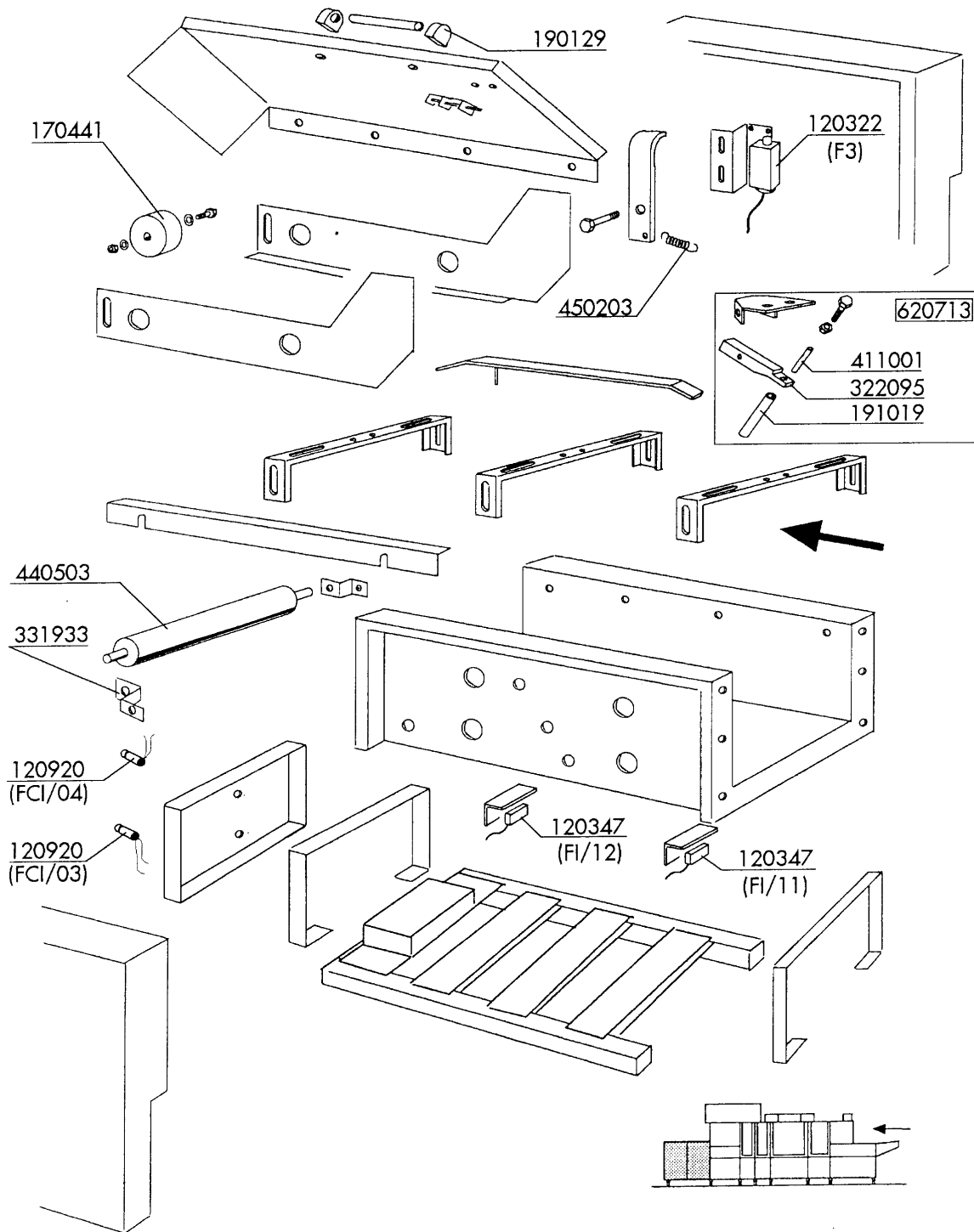

14 - Exit table

CODE	DESCRIPTION
120322	TRAY WASHER LIMIT SWITCH
120347	REED (NC)
120920	PHOTOCEL: CART READY/FULL
170441	ROLL FOR LV
190129	HANDLE SUPPORT SE NE GREY
191019	MAGNET HOUSING S90 MOPL.-S.N.L
322095	LEVER
331933	BRACKET FOR LVP ROLLER
411001	PERMANENT MAGNET 8X40
440503	ROLLERS F.SLAT BELT 1062V
450203	STAINL.ST.MICRO SPRING D.10
620713	MAGN.SWITCH

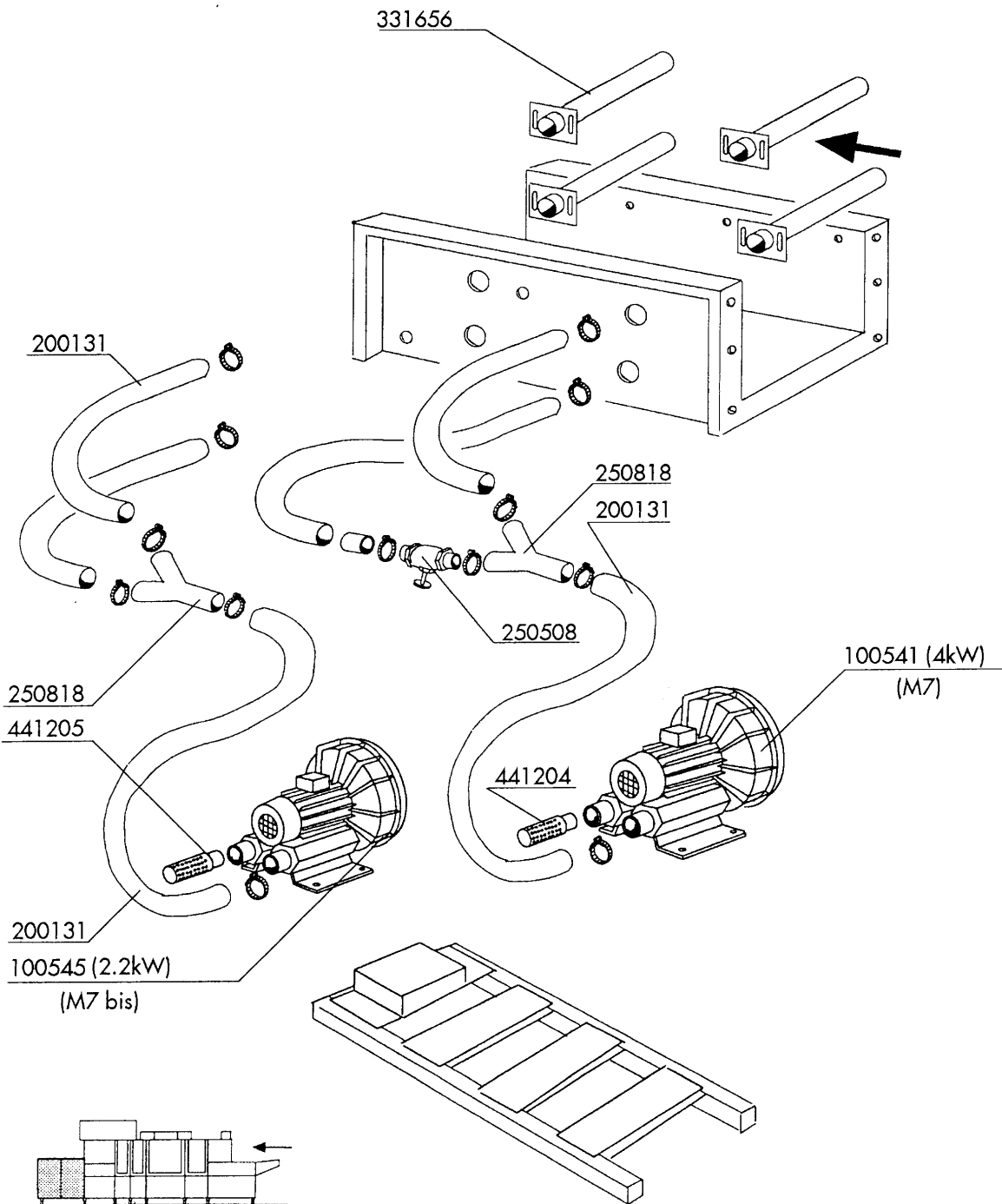

15 - Trays Dryer

CODE	DESCRIPTION
100541	VENTILATOR FOR DRYER LVP 4KW
100545	FAN 2.2KW 2.ND DRYER TRAY WASH
200131	HOSE D.50 PVC
250508	ELBOW 1"1/2
250818	CONNECTION "Y"
331656	AIR JET WITH FLANGE
441204	FILTER FOR TRAY WASHER FAN
441205	STRAINER (441204)

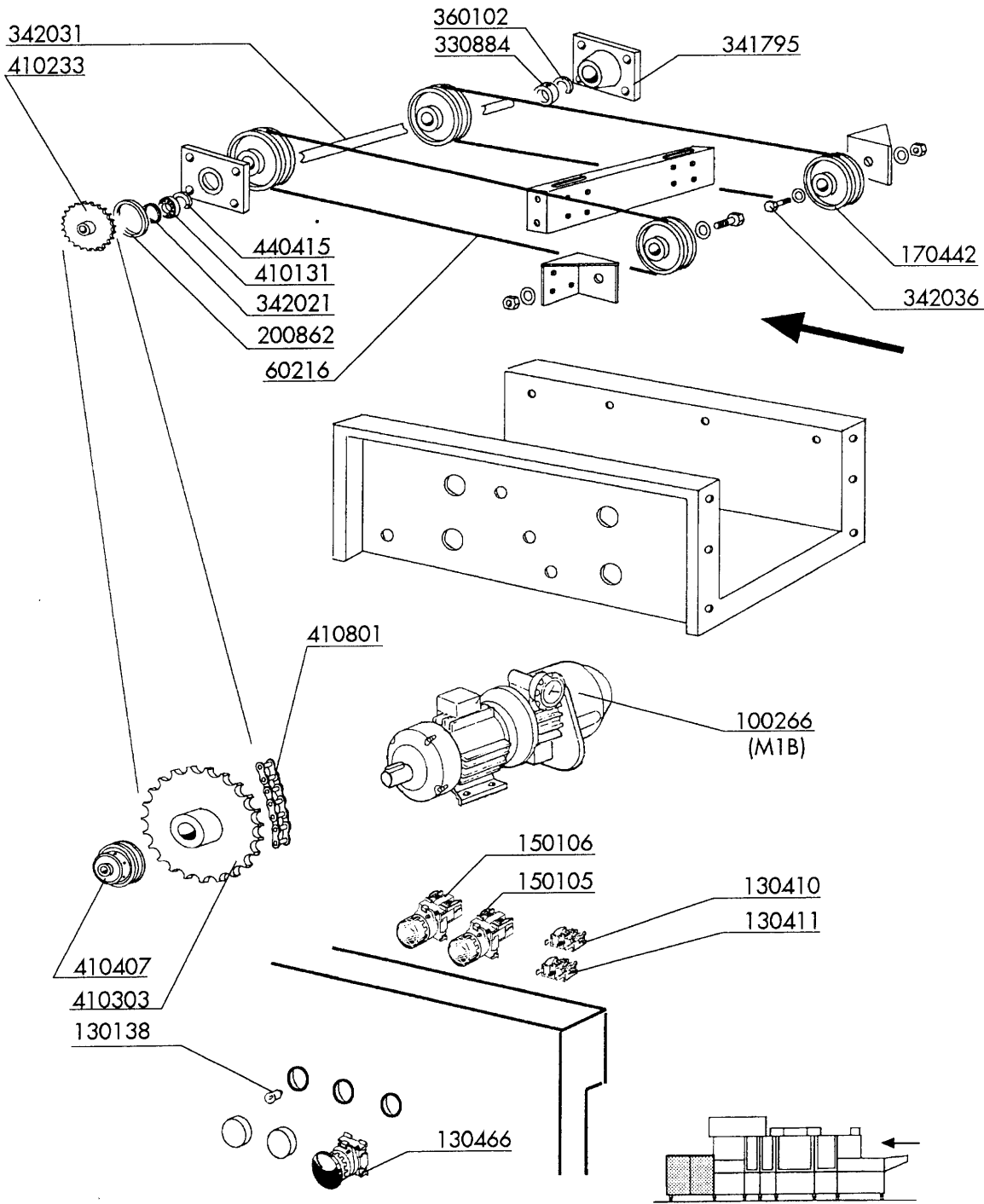

CODE	DESCRIPTION
100266	VARIABLE SPEED REDUCER 0,22KW
130138	LIGHT WITH BAYONET COUPLING 3W
130410	STOP CONTACT F40 CN RED
130411	START CONTACT YELLOW
130466	EMERGENCY SWITCH
150105	LAMP RED D.22X5
150106	LAMP GREEN 22X5
170442	WHEEL FOR POLYCORD
200862	GASKET OR
330884	WASHER
341795	BEARINGS SUPPORT
342021	SPACER
342031	CONVEYOR PIN FOR DRYER
342036	SPINDLE FOR WHEEL
360102	WASHER
410131	S/S BALL BEARING 6004 2RS 20X4
410233	TURND PINION Z14-1/2"-D.17
410303	CROWN DISCS 50T 1/2" PITCH
410407	TORQUE LIMITER LC 1
410801	DRIVE CHAIN 1/2" N-S
440415	GASKET MIM 20X30X5 (VITON)
60216	CORD OF POLYCORD D.12MM

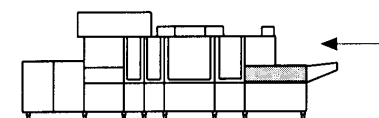
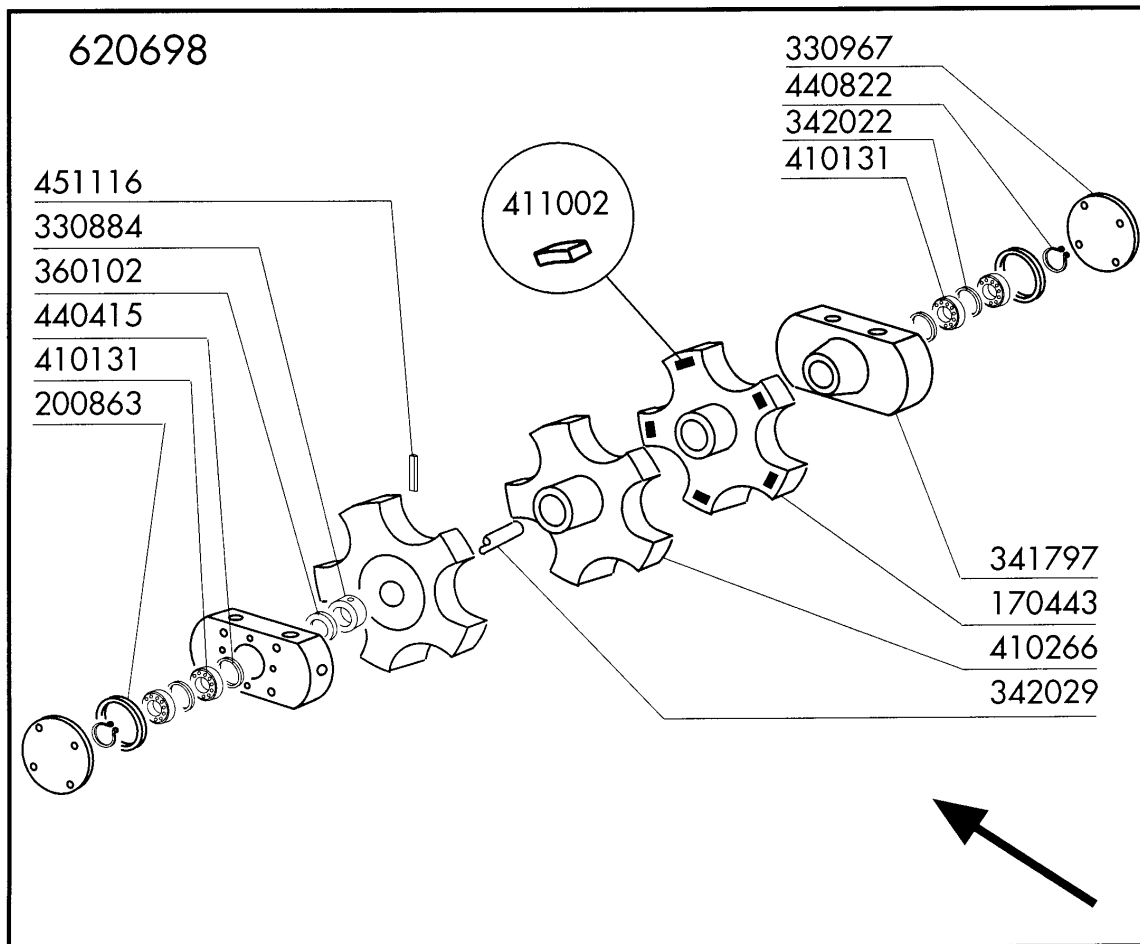
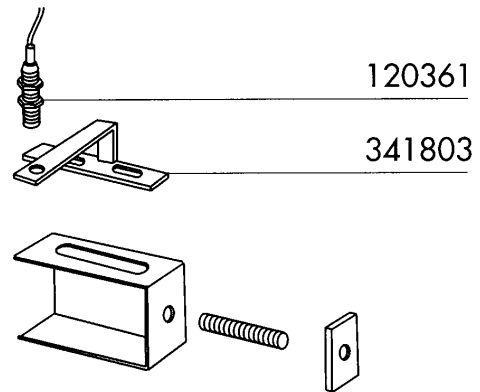

17 - Idle wheels

CODE	DESCRIPTION
120361	SENSOR
170443	TURNTD PINION WITH BUTTON HOLE
200863	GASKET OR
330884	WASHER
330967	FLANGE
341797	BEARING SUPPORT
341803	MAGN.SWITCH SUPPORT
342022	WASHER
342029	SPINDLE
360102	WASHER
410131	S/S BALL BEARING 6004 2RS 20X4
410266	PINION Z=5
411002	PERMANENT MAGNET 24X12
440415	GASKET MIM 20X30X5 (VITON)
440822	SEEGER
451116	ELASTIC PIN 6X40
620698	SPINDLE

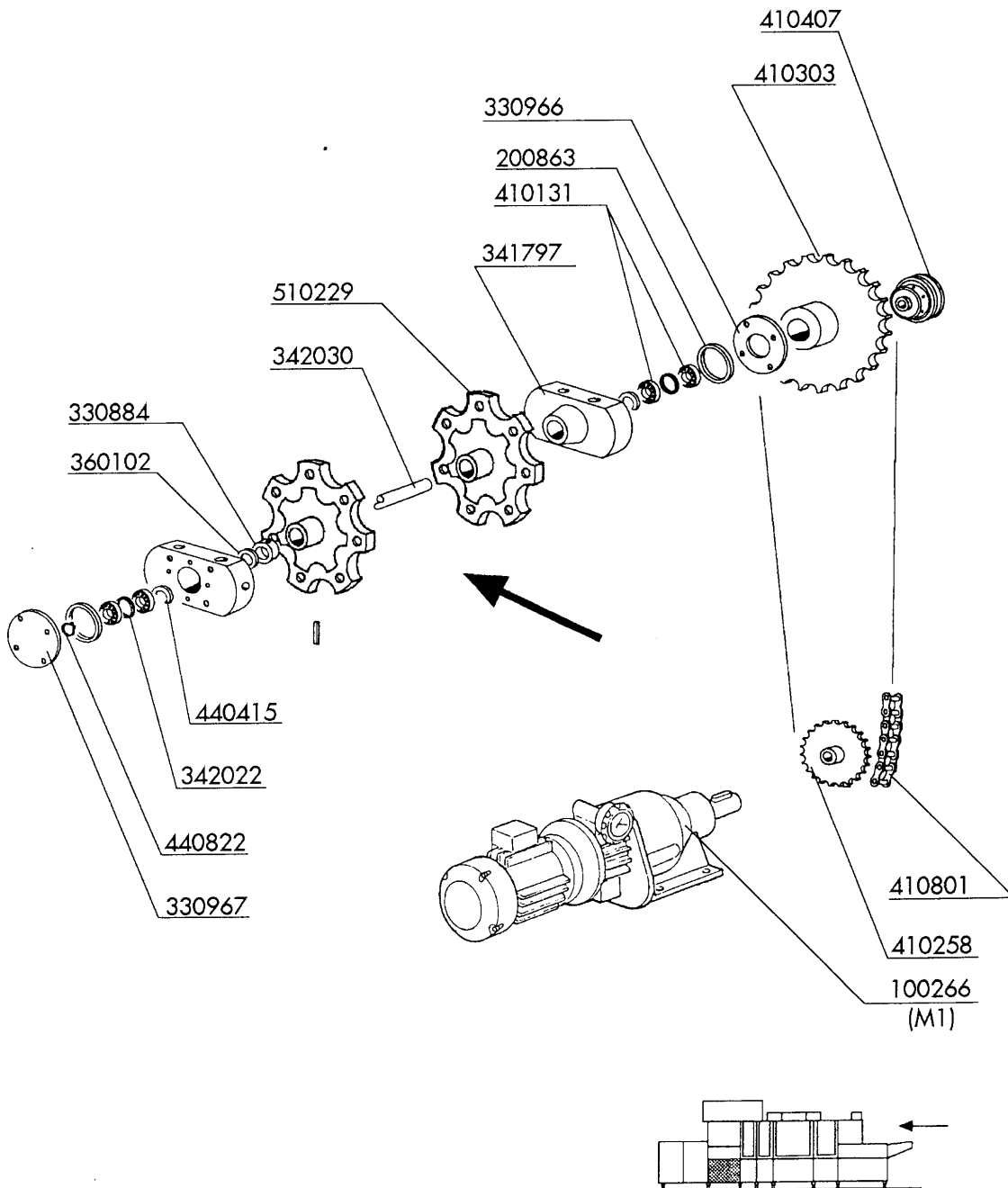

18 - Drive wheels

CODE	DESCRIPTION
100266	VARIABLE SPEED REDUCER 0,22KW
200863	GASKET OR
330884	WASHER
330966	FLANGE
330967	FLANGE
341797	BEARING SUPPORT
342022	WASHER
342030	CONVEYOR SPINDLE
360102	WASHER
410131	S/S BALL BEARING 6004 2RS 20X4
410258	PINION Z13-1/2" 19
410303	CROWN DISCS 50T 1/2" PITCH
410407	TORQUE LIMITER LC 1
410801	DRIVE CHAIN 1/2" N-S
440415	GASKET MIM 20X30X5 (VITON)
440822	SEEGER
510229	DRIVE SHAFT SPROCKET

19 - Trays and cutlery conveyor

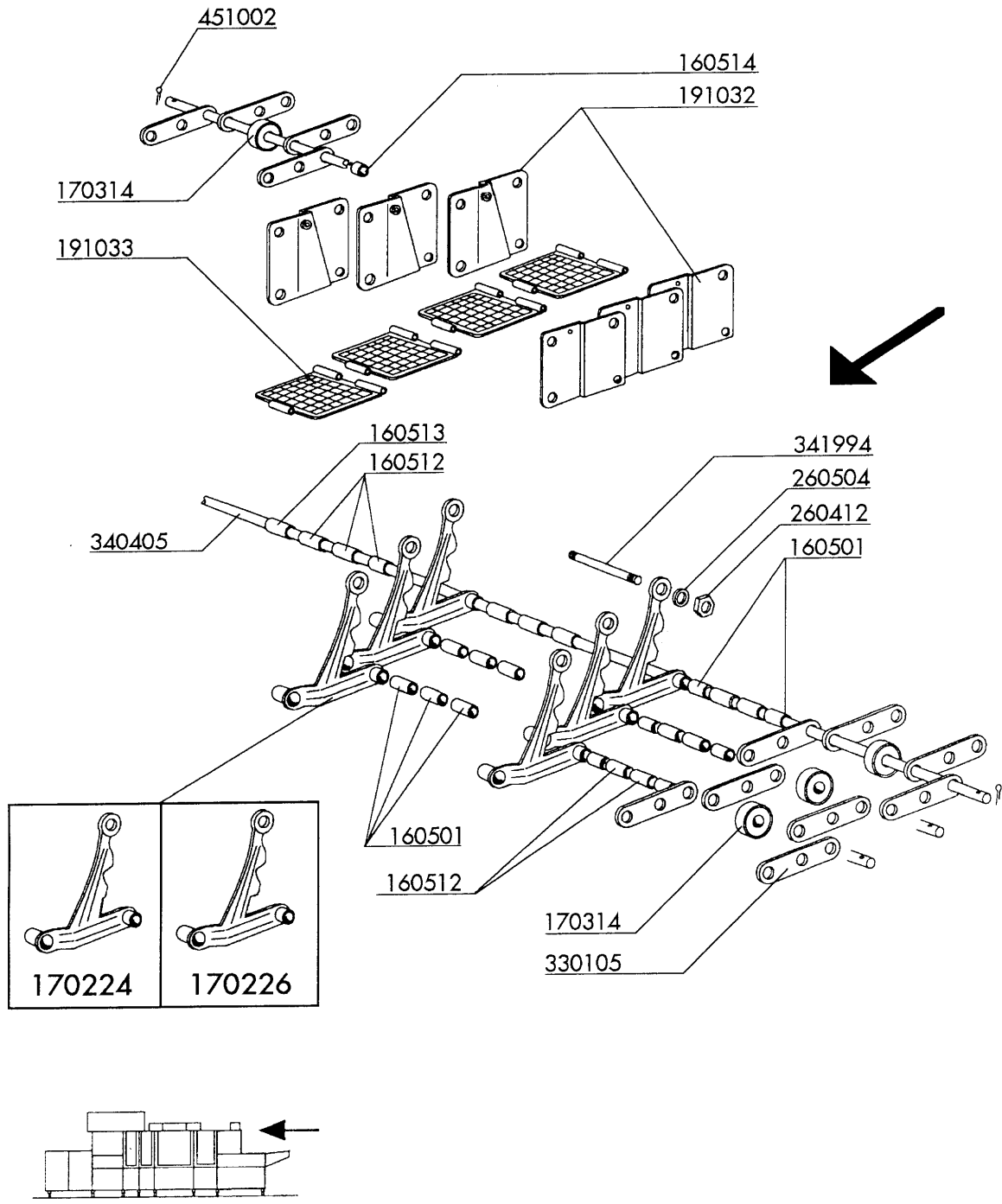

19 - Trays and cutlery conveyor

CODE	DESCRIPTION
160501	SPACER FLIGHT D.9X25 CONVEYOR
160512	SPACER 35,5
160513	SPACER 27,8
160514	SPACER 7,9 108378 MOP
170224	FINGER FOR TRAY WASHER
170226	FINGER FOR LVP - DISTANCE 69
170314	GRAY BELTWHEEL N
191032	SIDE ELEM. F. BELT OF CUTLERY
191033	GRID F. BELT OF CUTLERY
260412	SELF-LOCKING NUT M6
260504	ST/ST FLAT WASHER D6
330105	LINKS 2 FOR BELT NST.88
340405	SHAFT FOR BELTN D.8X611
341994	SPINDLE FOR TRAY WASHER
451002	COTTER PIN STAINL.ST. D2X12

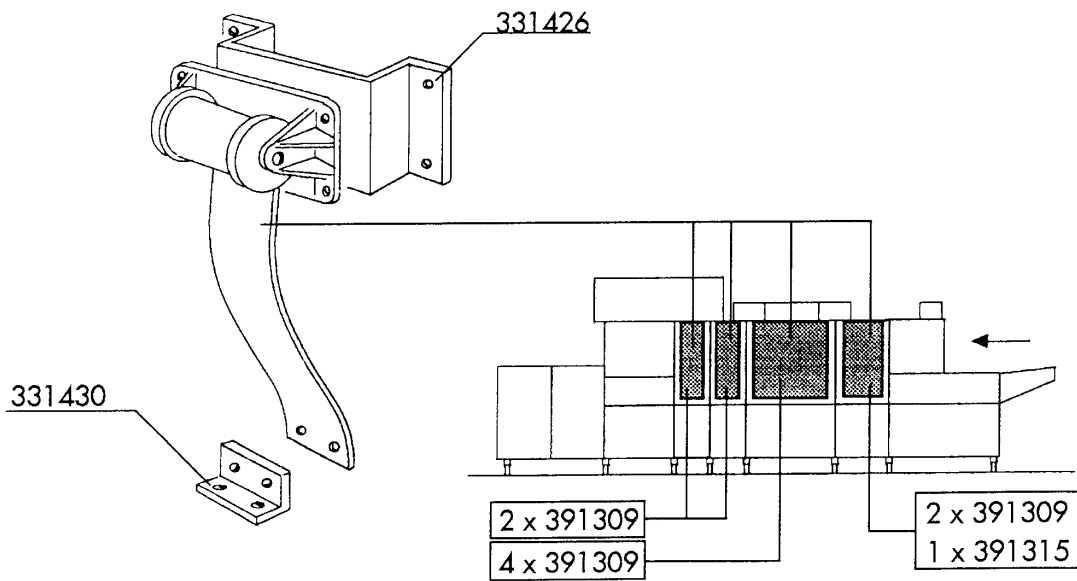
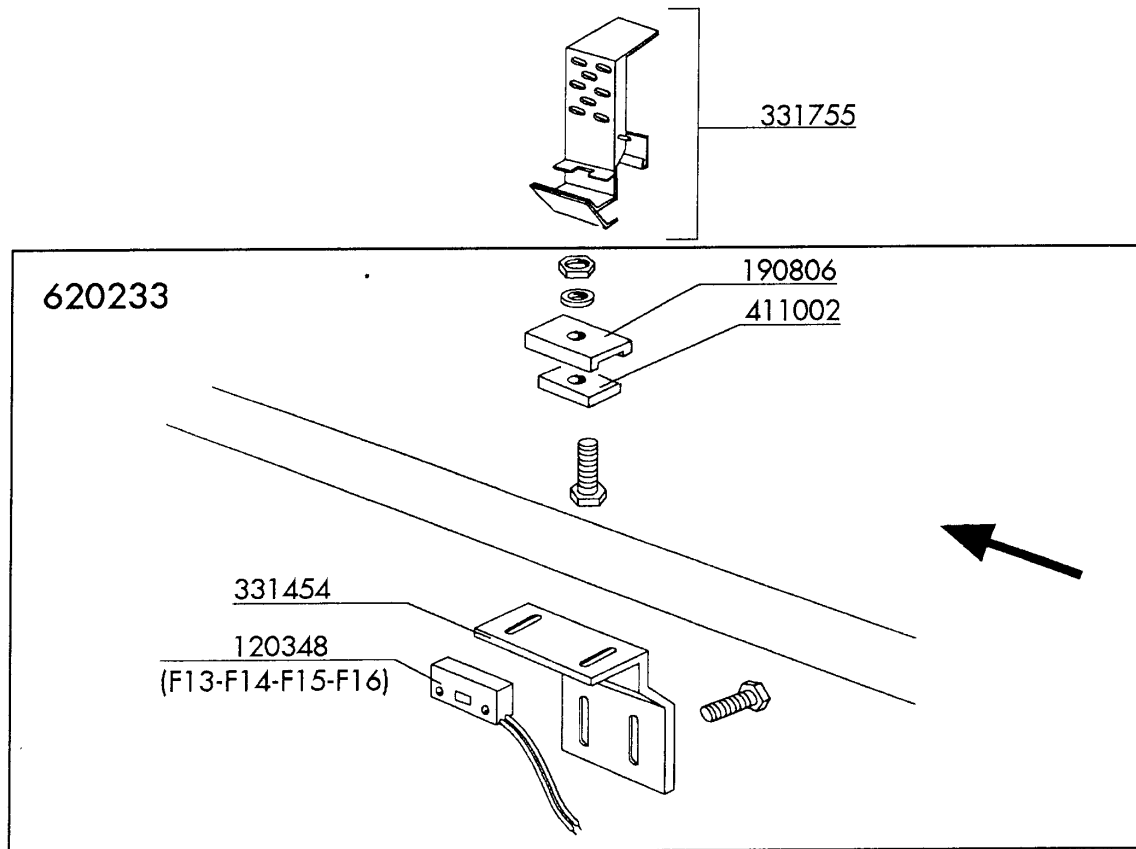

20 - Springs and door switch

CODE	DESCRIPTION
120348	MAGN.SWITCH (N.O.)
190806	MAGNET HOUSING
331426	BRACKET F. HOOD SPRING FIXING
331430	BRACKET FOR DOOR SPRING
331454	MICRO SWITCH BRACKET
331755	HOOK FOR DOOR SUPPORT
391309	DOOR SPRING 4KG - 40MM
391315	DOOR SPRING 2,5KG - 40MM
411002	PERMANENT MAGNET 24X12
620233	DOOR MAGN.SWITCH G/NE/NG/LV

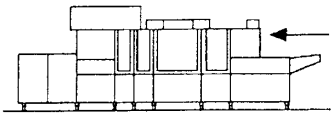
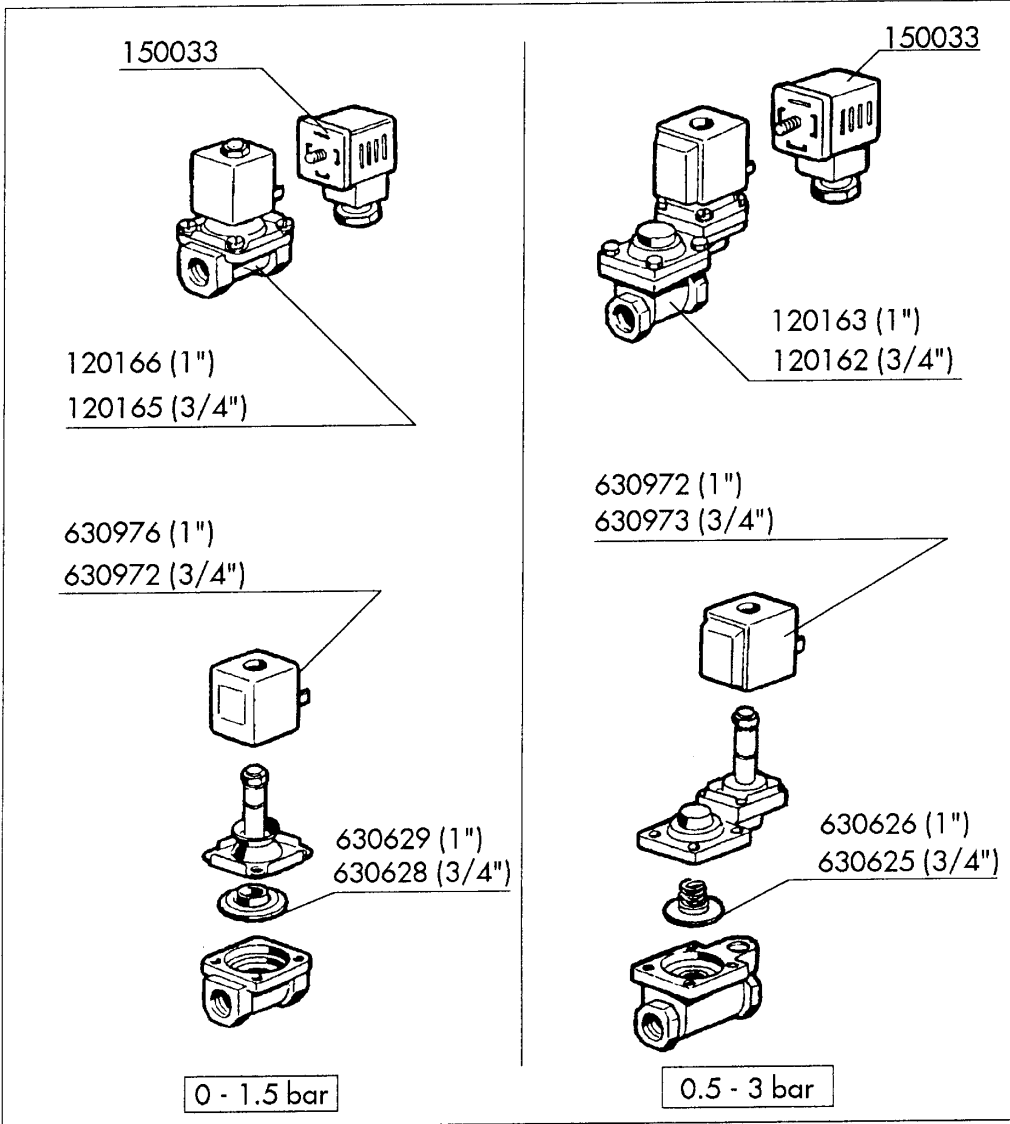

21 - Steam solenoid valve

CODE	DESCRIPTION
120162	SOLENOID VALVE L145R1Z734A 3/4
120163	SOLEN.VAL.ST.L145R1Z234A 1"24V
120165	SOLEN.VALVE ST.24V50HZ 3/4"
120166	STEAM SOLEN.VALVE 1" 24V-50
150033	CONNEC.F.SOLEN.VALVE 182.09.N
630625	KIT F.SOLEN.VALVE
630626	KIT FOR SOLENOID VALVE 145 1"
630628	KIT F.SOLEN.V.L153D1 3/4"
630629	KIT SOLENOID VALVE 1" STEAM L1
630972	COIL Z534A/V.24-L145A-3/4
630973	COIL Z614A/V.24-L145-3/4 A
630976	COIL Z114A/V24/50HZ L153-1"

100703 (1.1kW 400V 50Hz)

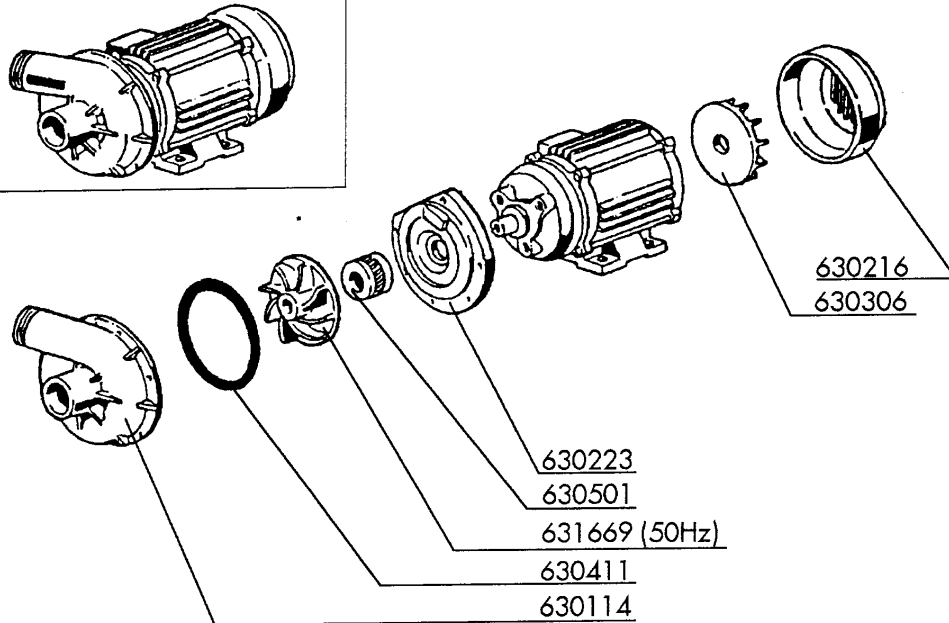

100361 (1.5kW 400V 50Hz)

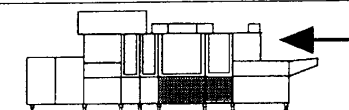
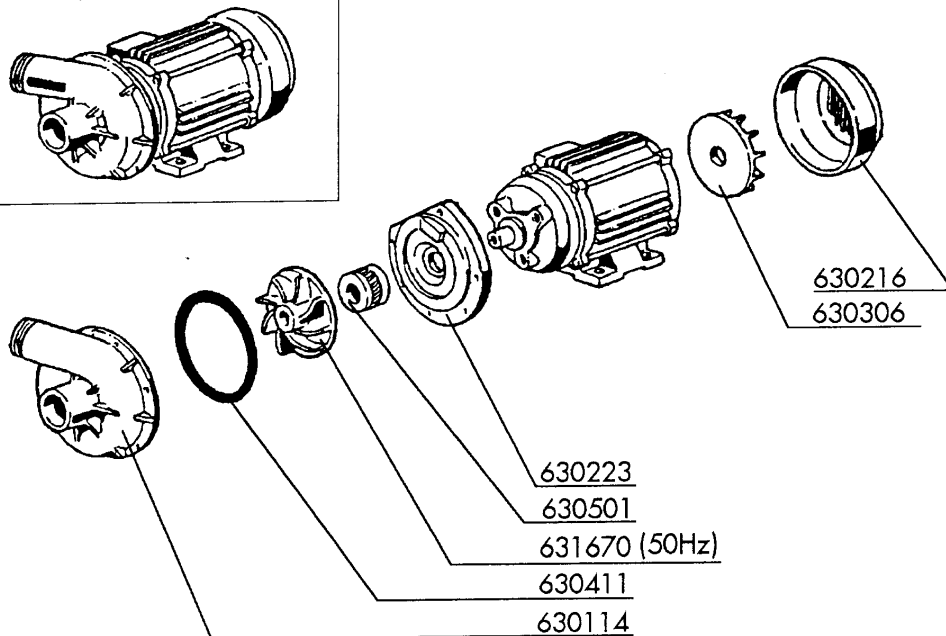

22 - Pump

CODE	DESCRIPTION
100361	PUMP HP 2-220/380-50HZ-120404
100703	PUMP 1,5HP 220/380 50HZ 1241
630114	VOLUTE FI HP2-2,7-3-3,2
630216	FAN HOUSING FIR HP 2-3
630223	BACK PLATE PUMP HP2-3-3,2
630306	PUMP FAN IMPELLOR FI HP.2-3
630411	O-RING PUMP FI HP 2-2,7
630501	SEAL FOR PUMP HP 2-3-3,2
631669	ST/ST IMPELLER 1,5HP 1241
631670	ST/ST IMPELLER PUMP 1204 2HP 5

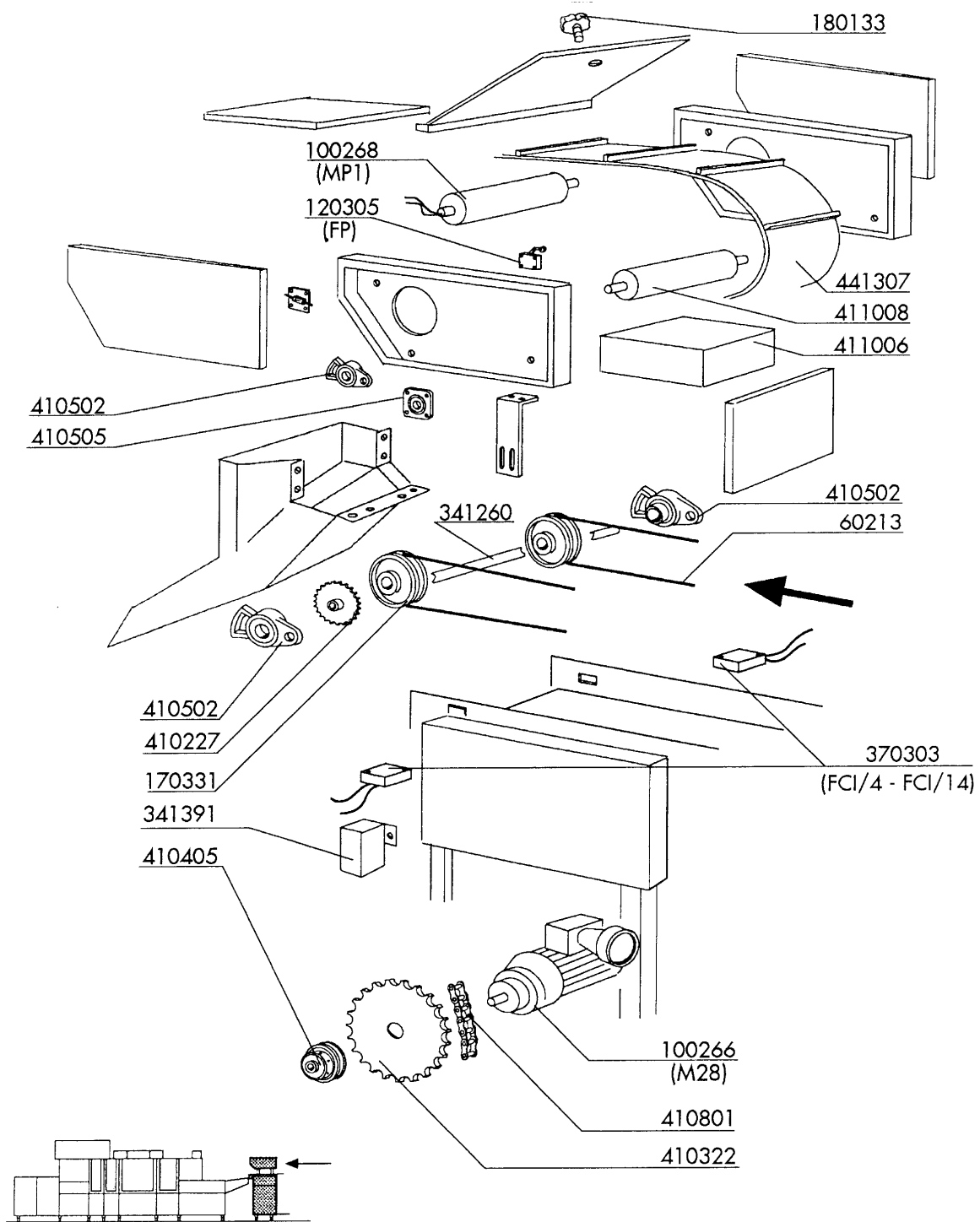

23 - Cutlery holder

CODE	DESCRIPTION
100266	VARIABLE SPEED REDUCER 0,22KW
100268	CYLINDER WITH MOTOR
120305	MICRO SWITCH WITH LEVER
170331	PULLEY FOR POLYCORD
180133	HANDLE FOR RP
341260	SPINDLE FOR POLYCORD WHEEL
341391	CONVEYOR PHOTOCELL SUPPORT
370303	PHOTOCELL
410227	TURNED PINION Z16-1/2"-D.20
410322	CROWN DISC Z50 1/2"
410405	TORQUE LIMITER D.25 NTP SE/1
410502	SUPPORT UCFA 204 D.20
410505	SUPPORT
410801	DRIVE CHAIN 1/2" N-S
411006	MAGNET
411008	MAGNETIC ROLLER
441307	BELT FOR CUTLERY HOLDER
60213	CORD OF POLYCORD D.15

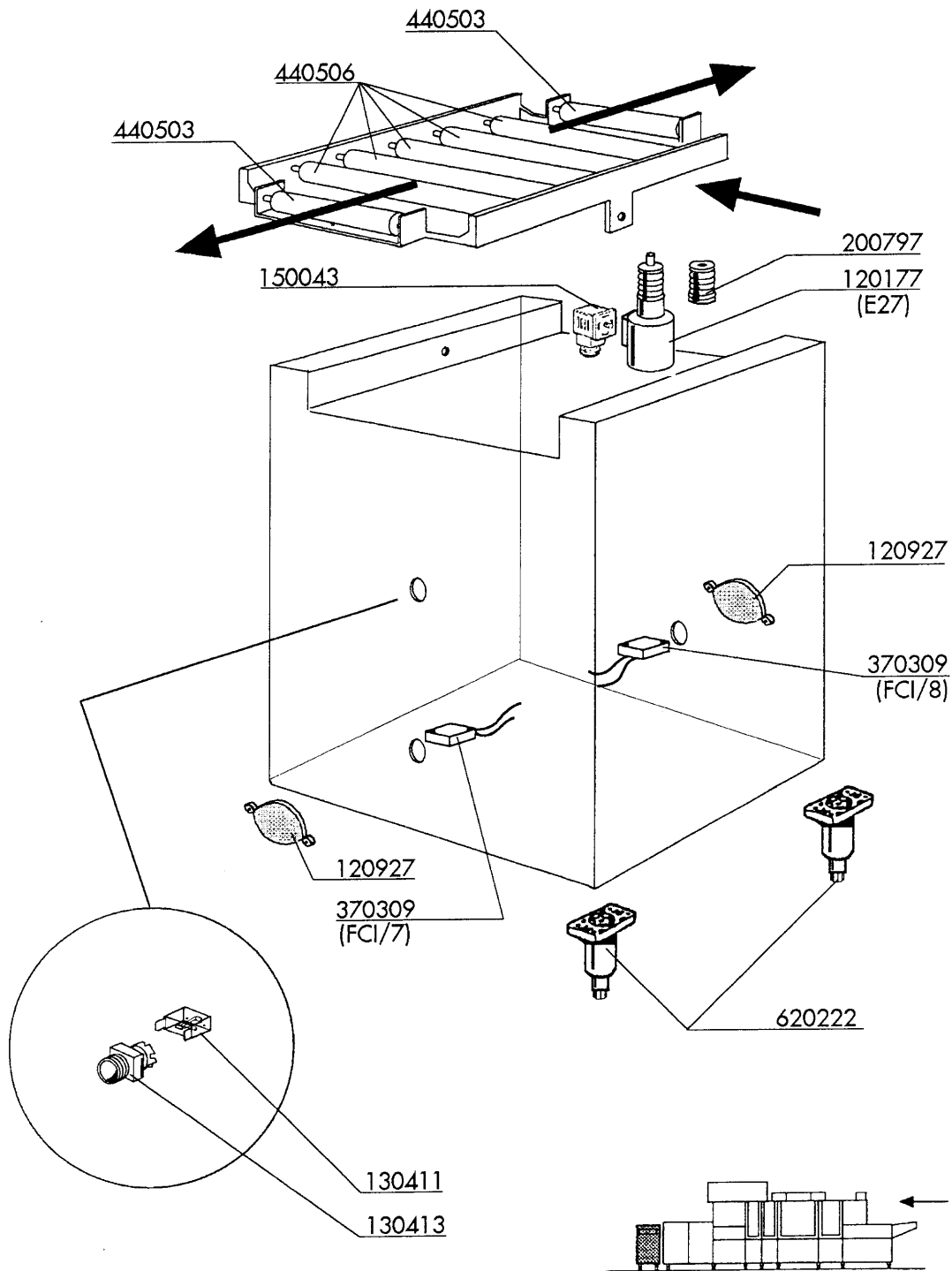

24 - Trays deviator

CODE	DESCRIPTION
120177	ELECTROMAGNET -E27- CS70 24V F
120927	REFLECTOR
130411	START CONTACT YELLOW
130413	GREEN PUSH BUTTON
150043	CONNECTOR FOR ELECTROMAGN.
200797	SOFFIETTO X ELETTRON.BALBONI \$
370309	PHOTOCELL WITH REFLECTOR LVP2
440503	ROLLERS F.SLAT BELT 1062V
440506	ROLLER 50X550 SHAFT+BEARINGS
620222	COMPLETE ALUMINIUM LEGS

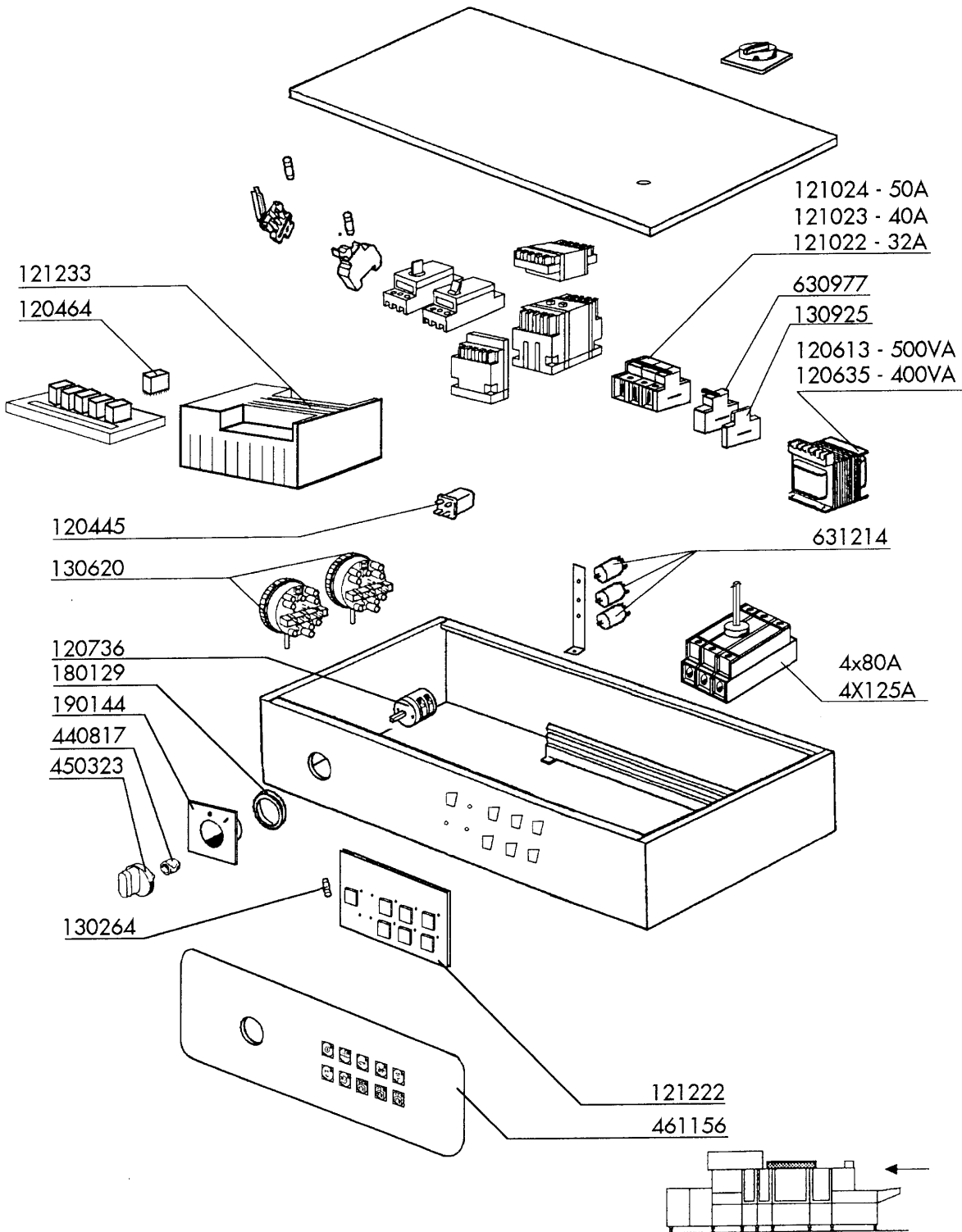

25 - Control panel

CODE	DESCRIPTION
120445	AUXILIARY RELAY S.B2/3 24V
120464	RELAY 10A
120613	TRANSFORMER 500VA 220-240-380-
120635	TRANSFORMER 400VA220-240-380-4
120736	4 POLE MAIN SWITCH 25A 500V
121022	CIRCUIT BREAKER 32A
121023	CIRCUIT BREAKER 40A
121024	CIRCUIT BREAKER 50A
121222	PCB FOR TRAY WASHER
121233	PLC FOR TRAY WASHER
130264	FUSE 5X20 1A
130620	PRESSURE SWITCH 3 LEVEL 50-30/
130925	CONTACT FOR CIRCUIT BREAKER
180129	NUT FOR MAIN SWITCH SUPPORT
190144	MAIN SWITCH HOLDER
440817	SNAP RING LSCB/1853/17/00
450323	KNOB FOR BC-BR-C95-C155
461156	PLATE LV-LVP
630977	COIL FOR CIRCUIT BREAKER 24V
631214	ANTI-NOISE FILTER 4011135007 3

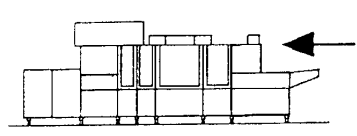
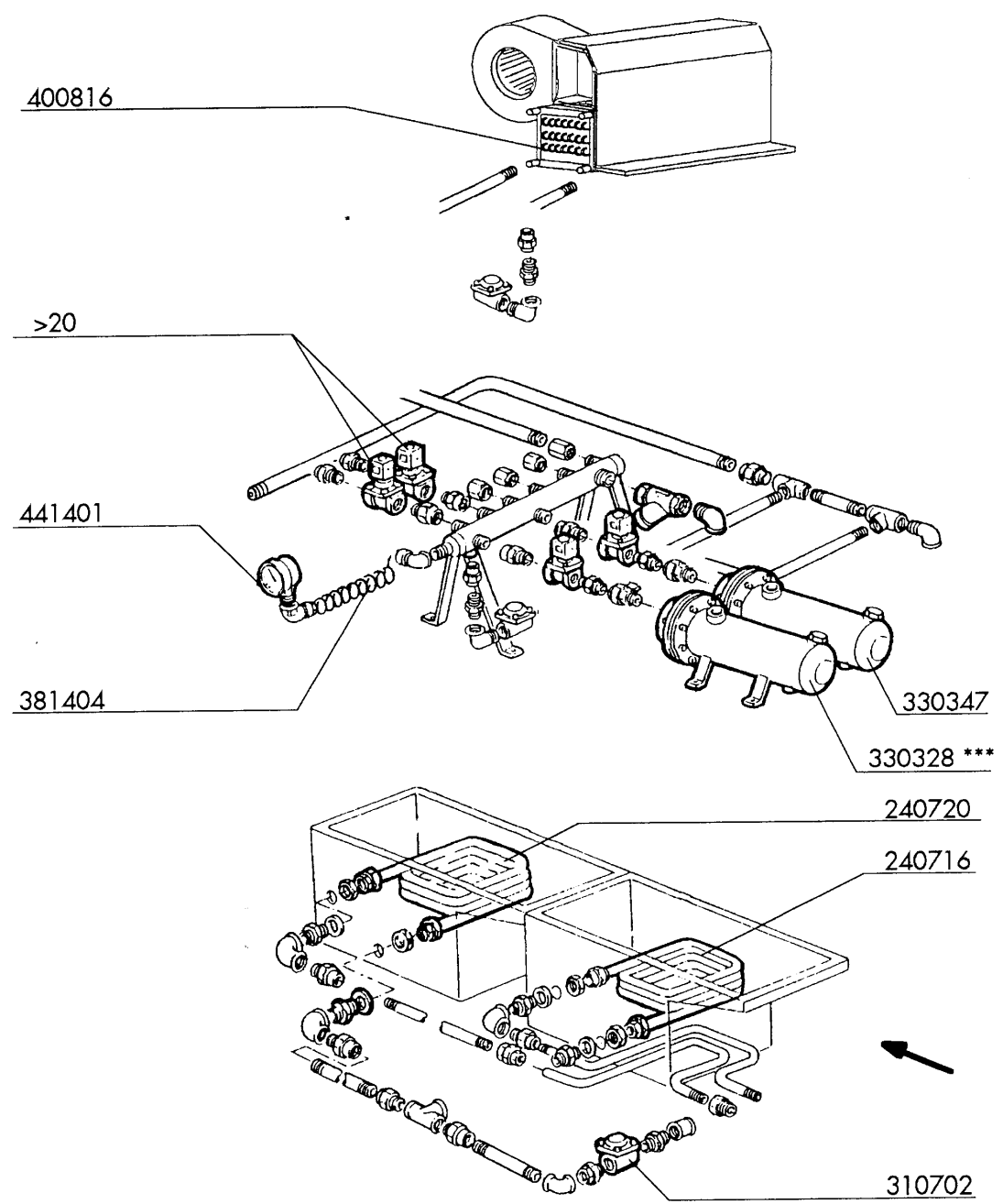

- *** Solo per risciacquo ad osmosi
- *** Rinçage deminéralisé
- *** Für Osmosenachspülung
- *** For osmosis rinse

26 - Steam Version

CODE	DESCRIPTION
240716	STEAM COIL G66-S3
240720	S/S STEAM COIL 12.000KCAL ACR/
310702	STEAM TRAP 1/2" MK 25/3
330328	STEAM BOILER G
330347	BOOSTER INOX/INOX 30000KCAL
381404	HOSE STEAM GAUGE
400816	BATTERY FOR DRYING (6KW) S
441401	PRESSURE GAUGE 60 SCALO-4CR1/4